

C65 Microturbine

Landfill Gas



Achieve ultra-low emissions and reliable electrical generation from landfill gas.

- + Ultra-low emissions
- + Accepts sour gas fuels with up to 5,000 ppm H₂S
- + One moving part – minimal maintenance and downtime
- + Patented air bearings – no lubricating oil or coolant
- + Integrated utility synchronization – no external switchgear
- + Compact modular design allows for easy, low-cost installation
- + Multiple units easily combined – act as single generating source
- + Remote monitoring and diagnostic capabilities
- + Proven technology with tens of millions of operating hours
- + Various Factory Protection Plans available



C65 Microturbine

Electrical Performance⁽¹⁾

Electrical Power Output ⁽²⁾	65kW
Voltage	400/480 VAC
Electrical Service	3-Phase, 4 Wire Wye
Frequency	50/60 Hz
Electrical Efficiency LHV	29%

Fuel/Engine Characteristics⁽¹⁾

Landfill Gas HHV	13.0–22.4 MJ/m ³ (350–600 BTU/scf)
H ₂ S Content	< 5,000 ppmv
Inlet Pressure	517– 551 kPa gauge (75–80 psig)
Fuel Flow HHV	888 MJ/hr (842,000 BTU/hr)
Net Heat Rate LHV	12.4 MJ/kWh (11,800 BTU/kWh)

Exhaust Characteristics⁽¹⁾

NOx Emissions @ 15% O ₂	< 9 ppmvd (18 mg/m ³)
Exhaust Mass Flow	0.49 kg/s (1.08 lbm/s)
Exhaust Gas Temperature	309°C (588°F)

Dimensions & Weight⁽³⁾

Width x Depth x Height	0.76 x 1.95 x 2.08 m (30 x 77 x 82 in)
Weight	758 kg (1,671 lb)

Reliable power when and where you need it. Clean and simple.

Minimum Clearance Requirements⁽⁴⁾

Horizontal Clearance	
Left & Right	0.76 m (30 in)
Front	0.76 m (30 in)
Rear	0.91 m (36 in)

Acoustic Emissions

Nominal at Full Power at 10 m (33 ft) ⁽⁵⁾	70 dBA
--	--------

Certifications

- UL 2200 Listed
- CE Certified
- Certified to the following grid interconnection standards: UL 1741-SA, VDE, BDEW, CEI 0-16 and AS4777
- Compliant to California Rule 21

C65 Engine Components

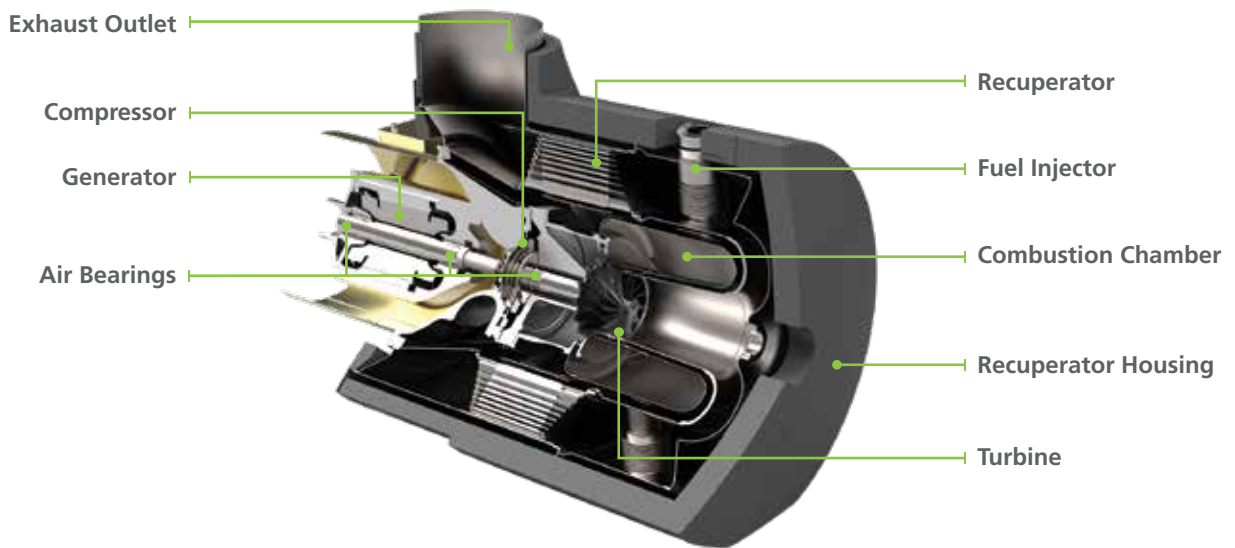

(1) Nominal full power performance at ISO conditions: 15°C (59°F), 14.696 psia, 60% RH

(2) Minimum power output is 35kW

(3) Approximate dimensions and weights

(4) Clearance requirements may increase due to local code considerations

(5) The optional acoustic inlet hood kit can reduce acoustic emissions at the front of the microturbine as much as 5 dBA
Specifications are not warranted and are subject to change without notice.