

C65 Microturbine

Digester Gas, ICHP



Achieve ultra-low emissions and reliable electrical/thermal generation from digester gas.

- + Ultra-low emissions
- + Accepts fuels with up to 5,000 ppm H₂S content
- + One moving part – minimal maintenance and downtime
- + Patented air bearings – no lubricating oil or coolant
- + Integrated utility synchronization – no external switchgear
- + Compact modular design allows for easy, low-cost installation
- + Multiple units easily combined – act as single generating source
- + Remote monitoring and diagnostic capabilities
- + Proven technology with tens of millions of operating hours
- + Various Factory Protection Plans available



C65 ICHP Microturbine

Electrical Performance⁽¹⁾

Electrical Power Output	65kW
Voltage	400/480 VAC
Electrical Service	3-Phase, 4 Wire Wye
Frequency	50/60 Hz
Electrical Efficiency LHV	29%

Fuel/Engine Characteristics⁽¹⁾

Digester Gas HHV	20.5–32.6 MJ/m ³ (550–875 BTU/scf)
H ₂ S Content	< 5,000 ppmv
Inlet Pressure	517– 551 kPa gauge (75–80 psig)
Fuel Flow HHV	888 MJ/hr (842,000 BTU/hr)
Net Heat Rate LHV	12.4 MJ/kWh (11,800 BTU/kWh)

Exhaust Characteristics⁽¹⁾

NO _x Emissions @ 15% O ₂	< 9 ppmvd (18 mg/m ³)
Exhaust Mass Flow	0.49 kg/s (1.08 lbm/s)
Exhaust Gas Temperature	309°C (588°F) (Heat Recovery Bypassed)

ICHP Heat Recovery⁽²⁾

Integrated Heat Recovery Module Type	Stainless Steel Core
Hot Water Heat Recovery	70kW (0.24 MMBTU/hr)

Reliable power when and where you need it. Clean and simple.

Dimensions & Weight⁽³⁾

Width x Depth x Height	0.76 x 2.20 x 2.53 m (30 x 87 x 100 in)
Weight - Grid Connect Model, dry	998 kg (2,200 lb)
Weight - Dual Mode Model, dry	1,364 kg (3,000 lb)

Minimum Clearance Requirements⁽⁴⁾

Horizontal Clearance	
Left & Right	0.76 m (30 in)
Front - Grid Connect Model	0.76 m (30 in)
Front - Dual Mode Model	1.65 m (65 in)
Rear	0.76 m (30 in)

Acoustic Emissions

Nominal at Full Power at 10 m (33 ft)	65 dBA
---------------------------------------	--------

Certifications

- UL 2200 Listed
- CE Certified
- Certified to the following grid interconnection standards: UL 1741-SA, VDE, BDEW, CEI 0-16 and AS4777
- Compliant to California Rule 21

C65 Engine Components

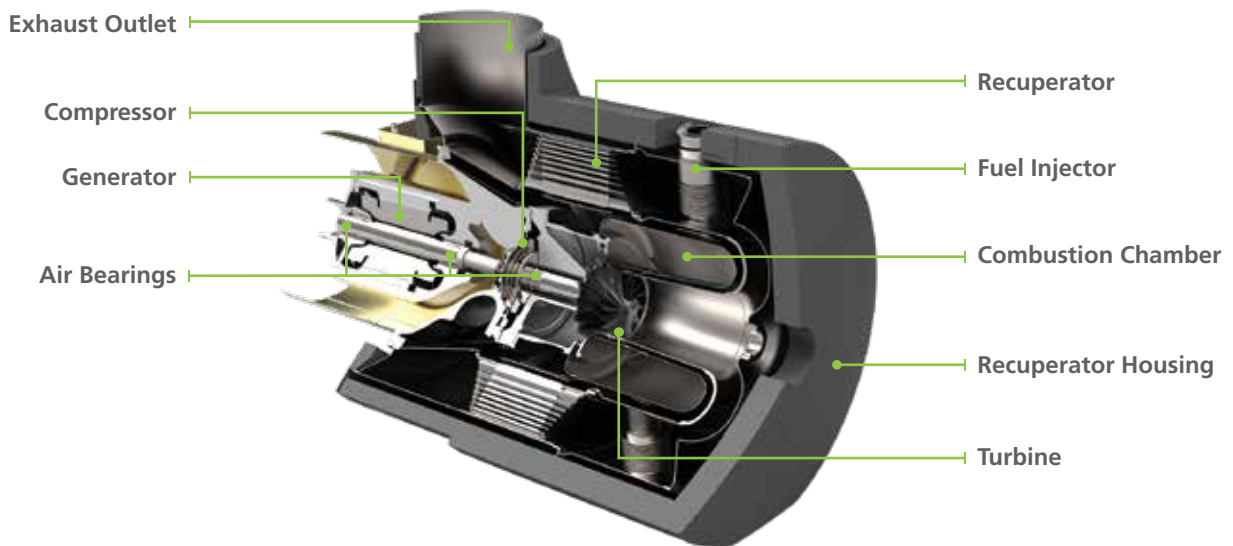

(1) Nominal full power performance at ISO conditions: 15°C (59°F), 14.696 psia, 60% RH
 (2) Nominal heat recovery for water inlet temperature of 60°C (140°F) and flow rate of 2.5 l/s (40 GPM)
 (3) Approximate dimensions and weights
 (4) Clearance requirements may increase due to local code considerations
 Specifications are not warranted and are subject to change without notice.

