

# C800S Power Package

High-pressure Natural Gas, ICHP

The Signature Series Microturbine provides ultra-low emissions and reliable electrical/thermal generation from natural gas.



C800S ICHP Power Package

## Electrical Performance<sup>(1)</sup>

Electrical Power Output	800kW
Voltage	400/480 VAC
Electrical Service	3-Phase, 4 Wire Wye
Frequency	50/60 Hz
Electrical Efficiency LHV	33%

## Fuel/Engine Characteristics<sup>(1)</sup>

Natural Gas HHV <sup>(2)</sup>	30.7–47.5 MJ/m <sup>3</sup> (825–1,275 BTU/scf)
Inlet Pressure	517–551 kPa gauge (75–80 psig)
Fuel Flow HHV	9,600 MJ/hr (9,120,000 BTU/hr)
Net Heat Rate LHV	10.9 MJ/kWh (10,300 BTU/kWh)

## Exhaust Characteristics<sup>(1)</sup>

NOx Emissions @ 15% O <sub>2</sub>	< 9 ppmvd (18 mg/m <sup>3</sup> )
Exhaust Mass Flow	5.3 kg/s (11.7 lbm/s)
Exhaust Gas Temperature	280°C (535°F) (Heat Recovery Bypassed)

## Benefits

- Ultra-low emissions
- One moving part – minimal maintenance and downtime
- Patented air bearings – no lubricating oil or coolant
- Integrated utility synchronization – no external switchgear
- Compact modular design allows for easy, low-cost installation
- High electrical efficiency over a very wide operating range
- High availability – part load redundancy
- Remote monitoring and diagnostic capabilities
- Proven technology with tens of millions of operating hours
- Various Factory Protection Plans available

**Smarter Energy  
for a Cleaner Future**

## Dimensions & Weight<sup>(3)</sup>

Width x Depth x Height	3.0 x 7.5 x 4.0 m (117 x 295 x 157 in)
Weight - Grid Connect Model, dry	17,400 kg (38,300 lbs)
Weight - Dual Mode Model, dry	20,200 kg (44,500 lbs)

## Minimum Clearance Requirements<sup>(4)</sup>

Horizontal Clearance	
Left	1.5 m (60 in)
Right	0.0 m (0 in)
Front	1.7 m (65 in)
Rear	2.2 m (85 in)

## ICHP Heat Recovery<sup>(5)</sup>

Hot Water Heat Recovery	1.2 MW (4.1 MMBtu/hr)
-------------------------	-----------------------

## Certifications

- UL 2200 Listed
- CE Certified
- Certified to the following grid interconnections standards: UL 1741-SA, VDE, BDEW, CEI 0-16, AS4777
- Compliant to California Rule 21

## C200 Engine Components

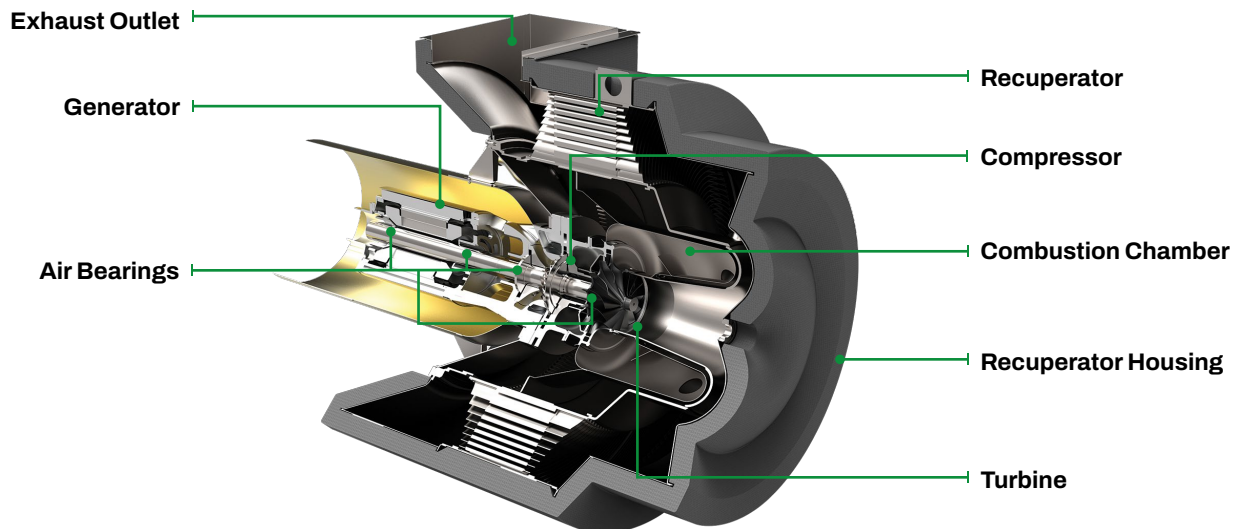

(1) Nominal full power performance at ISO conditions: 15°C (59°F), 14.696 psia, 60% RH

(2) Suitable for use with fuel blends containing up to 30 percent hydrogen gas by volume

(3) Approximate dimensions and weights

(4) Clearance requirements may increase due to local code considerations

(5) Nominal heat recovery using 4 Heat Recovery Modules (HRM). Inlet water temperature of 38°C (100°F) and flow rate of 6.3 l/s (100 gpm) per HRM

Specifications are not warranted and are subject to change without notice.