

C65 Microturbine

High-pressure Natural Gas



Achieve ultra-low emissions and reliable electrical generation from natural gas.

- + Ultra-low emissions
- + One moving part – minimal maintenance and downtime
- + Patented air bearings – no lubricating oil or coolant
- + Integrated utility synchronization – no external switchgear
- + Compact modular design allows for easy, low-cost installation
- + Multiple units easily combined – act as single generating source
- + Remote monitoring and diagnostic capabilities
- + Proven technology with tens of millions of operating hours
- + Various Factory Protection Plans available



C65 Microturbine

Electrical Performance⁽¹⁾

Electrical Power Output	65kW
Voltage	400/480 VAC
Electrical Service	3-Phase, 4 Wire Wye
Frequency	50/60 Hz
Electrical Efficiency LHV	29%

Fuel/Engine Characteristics⁽¹⁾

Natural Gas HHV	30.7–47.5 MJ/m ³ (825–1,275 BTU/scf)
Inlet Pressure	517– 551 kPa gauge (75–80 psig)
Fuel Flow HHV	888 MJ/hr (842,000 BTU/hr)
Net Heat Rate LHV	12.4 MJ/kWh (11,800 BTU/kWh)

Exhaust Characteristics⁽¹⁾

NOx Emissions @ 15% O ₂	< 9 ppmvd (19 mg/m ³)
Exhaust Mass Flow	0.49 kg/s (1.08 lbm/s)
Exhaust Gas Temperature	309°C (588°F)

Dimensions & Weight⁽²⁾

Width x Depth x Height ⁽³⁾	0.76 x 1.95 x 1.91 m (30 x 77 x 75 in)
Weight - Grid Connect Model	758 kg (1,671 lb)
Weight - Dual Mode Model	1,121 kg (2,471 lb)

Reliable power when and where you need it. Clean and simple.

Minimum Clearance Requirements⁽⁴⁾

Horizontal Clearance	
Left & Right	0.76 m (30 in)
Front - Grid Connect Model	0.76 m (30 in)
Front - Dual Mode Model	1.65 m (65 in)
Rear	0.91 m (36 in)

Acoustic Emissions

Nominal at Full Power at 10 m (33 ft) ⁽⁵⁾	70 dBA
--	--------

Certifications

- UL 2200 Listed
- CE Certified
- Certified to the following grid interconnection standards: UL 1741, VDE, and BDEW
- Compliant to California Rule 21

C65 Engine Components

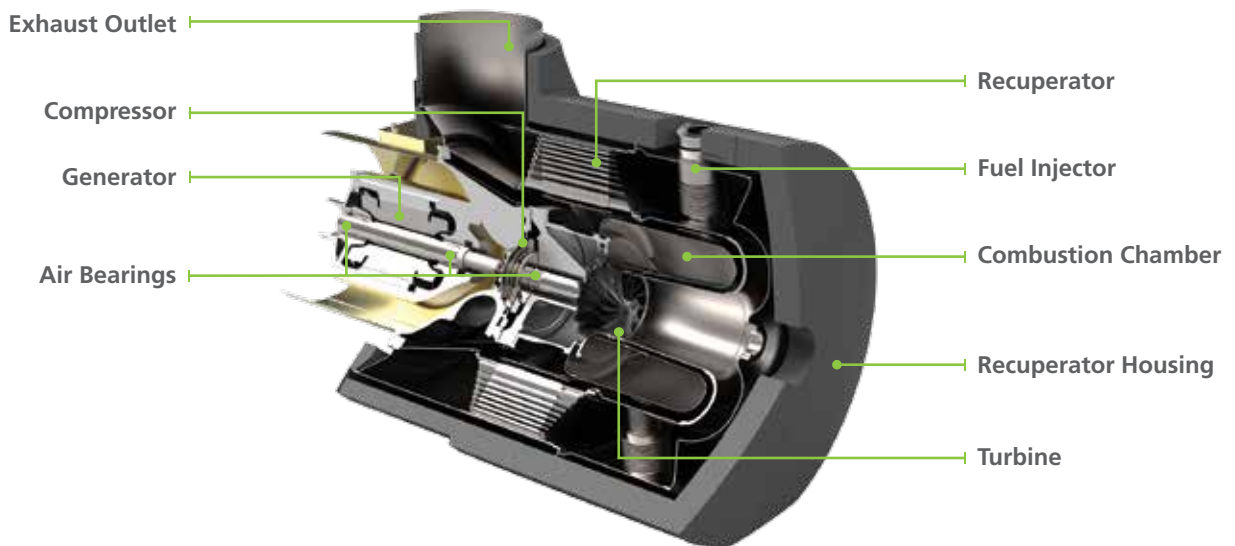

(1) Nominal full power performance at ISO conditions: 15°C (59°F), 14.696 psia, 60% RH

(2) Approximate dimensions and weights

(3) Height dimensions are to the roofline. Exhaust stack extends at least 178 mm (7 in) above the roofline

(4) Clearance requirements may increase due to local code considerations

(5) The optional acoustic inlet hood kit can reduce acoustic emissions at the front of the Microturbine as much as 5 dBA
Specifications are not warranted and are subject to change without notice.

