

Welcome to

# Analyst Day 2026



# Agenda



**Jennifer Rumsey**  
Chair and  
Chief Executive Officer



**Brett Merritt**  
President, Engine  
Business



**Jenny Bush**  
President, Power  
Systems Business



**Mark Smith**  
Chief Financial Officer

**The Power of Cummins**

**Proven Strength.  
Positioned for What's Next.**

**Unlocking Power  
Systems' Potential**

**Delivering Increasing  
Returns to Shareholders**

# Q+A Panel



**Jennifer Rumsey**  
Chair and Chief Executive Officer



**Brett Merritt**  
President, Engine Business



**Jenny Bush**  
President, Power Systems Business



**Mark Smith**  
Chief Financial Officer



**Amy Davis**  
President, Accelera and  
Components Business



**Shon Wright**  
President, Distribution Business

Information provided in this presentation that is not purely historical are forward-looking statements within the meaning of the Private Securities Litigation Reform Act of 1995, including statements regarding our forecasts, expectations, hopes, beliefs and intentions on strategies regarding the future. These forward-looking statements include, without limitation, statements relating to our plans and expectations for our revenues and EBITDA. Our actual future results could differ materially from those projected in such forward-looking statements because of a number of risks and uncertainties. More information regarding such risks and uncertainties is available in the forward-looking disclosure statement detailed in our Securities and Exchange Commission filings, particularly in the Risk Factors section of our 2025 Annual Report on Form 10-K, and any subsequently filed quarterly reports on Form 10-Q. Shareholders, potential investors and other readers are urged to consider these factors carefully in evaluating the forward-looking statements and are cautioned not to place undue reliance on such forward-looking statements. More detailed information about factors that may affect our performance may be found in our filings with the Securities and Exchange Commission, which are available at <http://www.sec.gov> or at <http://www.cummins.com> in the Investor Relations section of our website.

### **Presentation of Non-GAAP Financial Information**

EBITDA and ROIC are non-GAAP measures used in this presentation and are defined and reconciled to what management believes to be the most comparable GAAP measures in an appendix attached to this presentation. Cummins presents this information as it believes it is useful to understanding Cummins' operating performance, because EBITDA is a measure used internally to assess the performance of the operating units and because ROIC is a measure used internally to assess Cummins performance.



**Jennifer Rumsey**  
Chair and Chief Executive Officer

# The Power of Cummins

**Strengthened position, disciplined investment, stronger outlook**

**TODAY'S KEY TAKEAWAYS**

- Our global presence, broad portfolio, trusted partnerships and experienced people position us to win.
- We are investing and executing with discipline.
- We are delivering at record levels and raising our 2030 financial targets.

**SINCE ANALYST DAY 2024**

# **Raised our Performance. Advanced our Position.**

## **RAISED CYCLE OVER CYCLE PERFORMANCE**

**Achieved record  
results despite North  
America truck  
downcycle**

## **ADVANCING POWER SYSTEMS**

**Expanded capacity  
and strengthened  
long-term demand  
outlook**

## **FOCUSED ACCELERA INVESTMENT**

**Improved financial  
trajectory and  
disciplined  
participation**

## RAISING OUR TARGETS

### 2025 PERFORMANCE

**\$33.7B**

FY 2025 REVENUE

**17.4%**

\*FY 2025 EBITDA

### TODAY'S 2030 TARGETS

**↑ \$45-50B**

REVENUE IN 2030

**↑ >20.0%**

EBITDA MARGIN IN 2030

\*See Appendix for excluded one-time items

# Continuing to win and capture growth across the globe

## Worldwide reach

**190**

Countries and territories

**135**

Manufacturing facilities

**37**

R&D technical centers

## Largest integrated global distribution network

**640**

Distributor locations

**13k+**

Certified service locations

## Global leader in integrated powertrains

Medium and heavy-duty truck, bus and off-highway\*

## Global leader in high-horsepower engines, stand-by power and alternators

Data center | Mission-critical | Mining

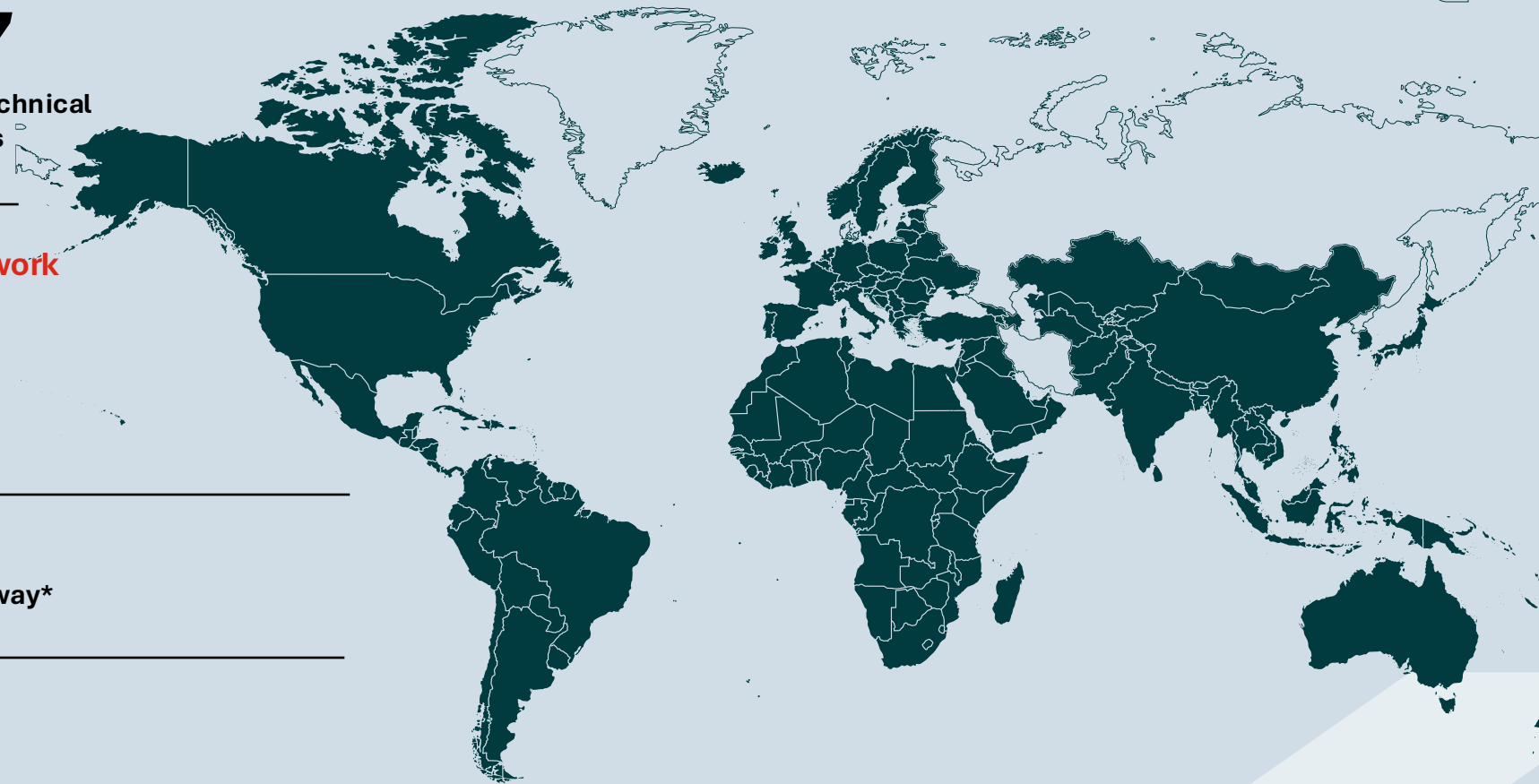

\*Above 4 liters

Disciplined investments reinforce and expand our leadership position in key markets

### HELM PLATFORMS



#### Strengthening the foundation

- Continuing investment in advanced diesel across B, X10 and X15 platforms
- Fuel-flexible solutions for 2027 and beyond

### POWER GENERATION SOLUTIONS



#### Advancing our position

- Expanding our portfolio and capacity to meet a strengthening data center outlook
- Leveraging our position and capability to provide more integrated solutions

### ADVANCING OUR TECHNOLOGIES

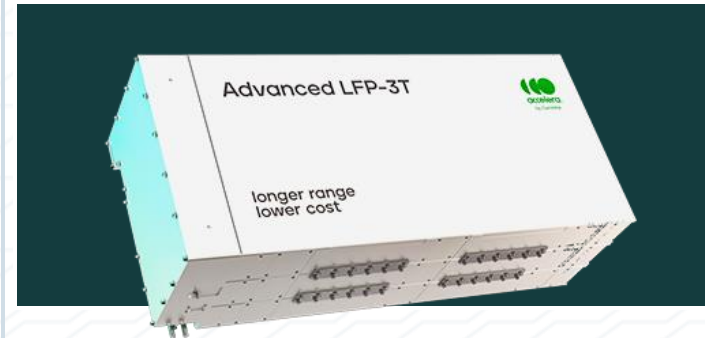

#### Delivering customer value

- Targeted investments in zero-emissions and bridge technologies
- Digital and AI enabled solutions

THE POWER OF OUR **PARTNERSHIPS**

Long-standing partnerships built on trust, reliability and local insight

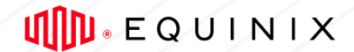

Deep, long-standing partnerships that have strengthened and expanded over time

Trusted application expertise built through performance and reliability

Decades of local market experience providing insight into regional requirements

Collaborative, solutions-driven partnerships that create win-win value for customers and Cummins

GLOBAL DISTRIBUTION AND SERVICE NETWORK UNDERPINS UPTIME AND CONFIDENCE

THE POWER OF OUR **PEOPLE**

# Experienced people drive performance



**EXPERIENCED LEADERS AND TEAMS**

**Strong leaders and teams with a proven ability to execute through complexity**



**APPLICATION EXPERTISE**

**Nearly 68,000 global employees translate deep application knowledge into innovation and dependable performance**



**SKILLED EMPLOYEES**

**Building skills and capabilities that enable our employees to deliver for today and tomorrow**

# PATH TO GROWTH AND MARGIN EXPANSION THROUGH **2030**

**HELM Platforms  
Launch**

**Power Generation  
Growth**

**Aftermarket  
Strength**

**Reduced Accelera  
Losses**

**Operational  
Excellence**

# Strengthened position, disciplined investment and a stronger outlook

## IN SUMMARY

- Our global presence, broad portfolio, trusted partnerships and experienced people position us to win.
- We are investing and executing with discipline.
- We are delivering at record levels and raising our 2030 financial targets.



**Brett Merritt**  
President, Engine Business

**ENGINE BUSINESS**

Proven strength.  
Positioned for  
what's next.

# Global scale. Strong partnership. Foundation for growth.

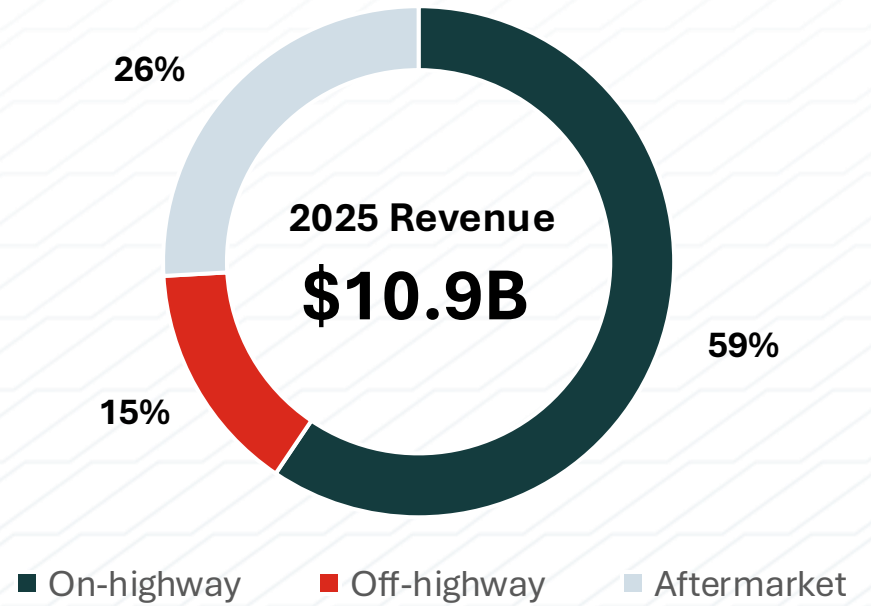
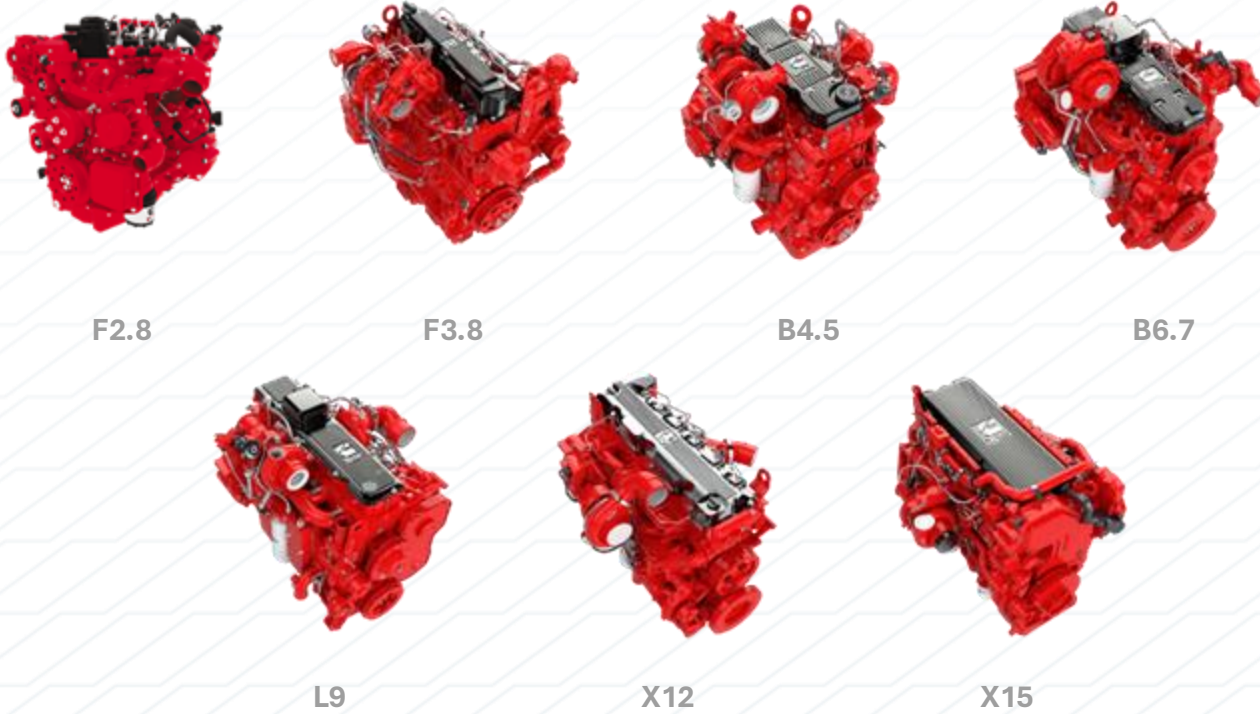

ON-HIGHWAY



OFF-HIGHWAY

AFTERMARKET

# Unmatched regional capability and market leadership



**1.3 million**

Engines sold in 2025

**#1 global market position\***

Medium- and heavy-duty truck  
Bus | Off-highway

\*Above 4 liters

**ENGINE BUSINESS**

# Built to perform through cycles

**EXPANDING  
ENGINE PRESENCE**

**New content,  
customer wins and  
markets returning in  
2027 and 2028.**

**AFTERMARKET  
ANNUITY GROWING**

**Growing engine  
population supports  
long-term growth in  
aftermarket.**

**PEAK INVESTMENT  
BEHIND US**

**New platforms  
and manufacturing  
investments largely  
complete.**

# Technology leadership that creates customer value

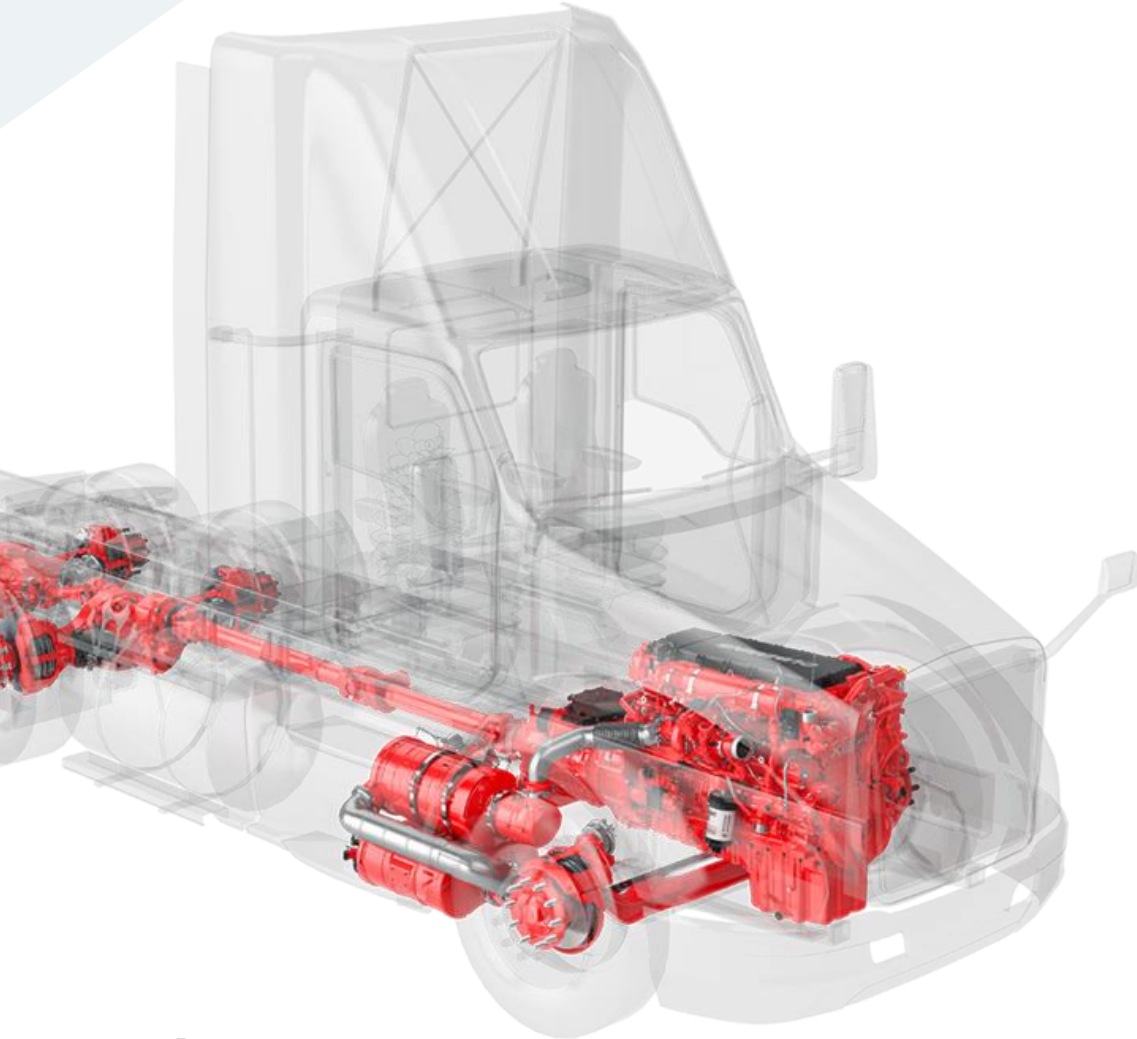

## FUEL CONSUMPTION

**14%**

Engine efficiency improvement since 2007

**+8%**

Powertrain efficiency improvement

## NOX LEVELS

**96%**

NOx reduction since 2007

2007

2027

# Positioned for what's next

**Cummins**  
**HELM**<sup>™</sup>  
HIGHER EFFICIENCY. LOWER EMISSIONS. MULTIPLE FUELS.

**B6.7**<sup>™</sup>  
OCTANE



**B7.2**<sup>™</sup>



**X10**<sup>™</sup>



**X15**<sup>™</sup>



Common platforms

Integrated systems

Industry-leading power density and packaging

# Turning product strength into market wins

## CREATE AVAILABILITY

Make Cummins Powertrain available across OEMs and product segments

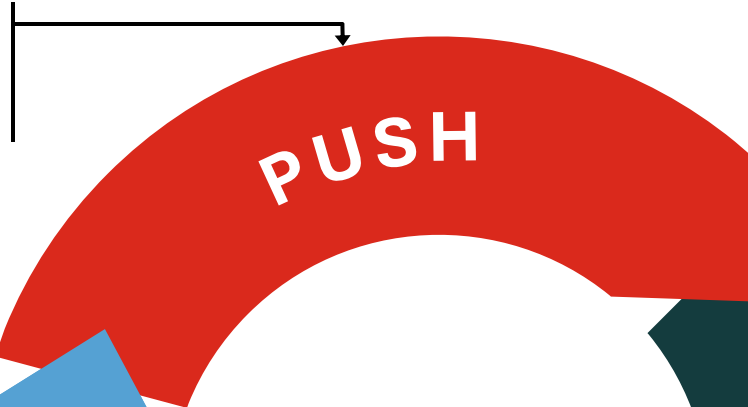

## CREATE PREFERENCE

Generate dealer and end customer preference for Cummins engines

## SUPPORT CUSTOMERS

Deliver best in class uptime and customer support

# Value that builds over time

**2.2M**

Active engines

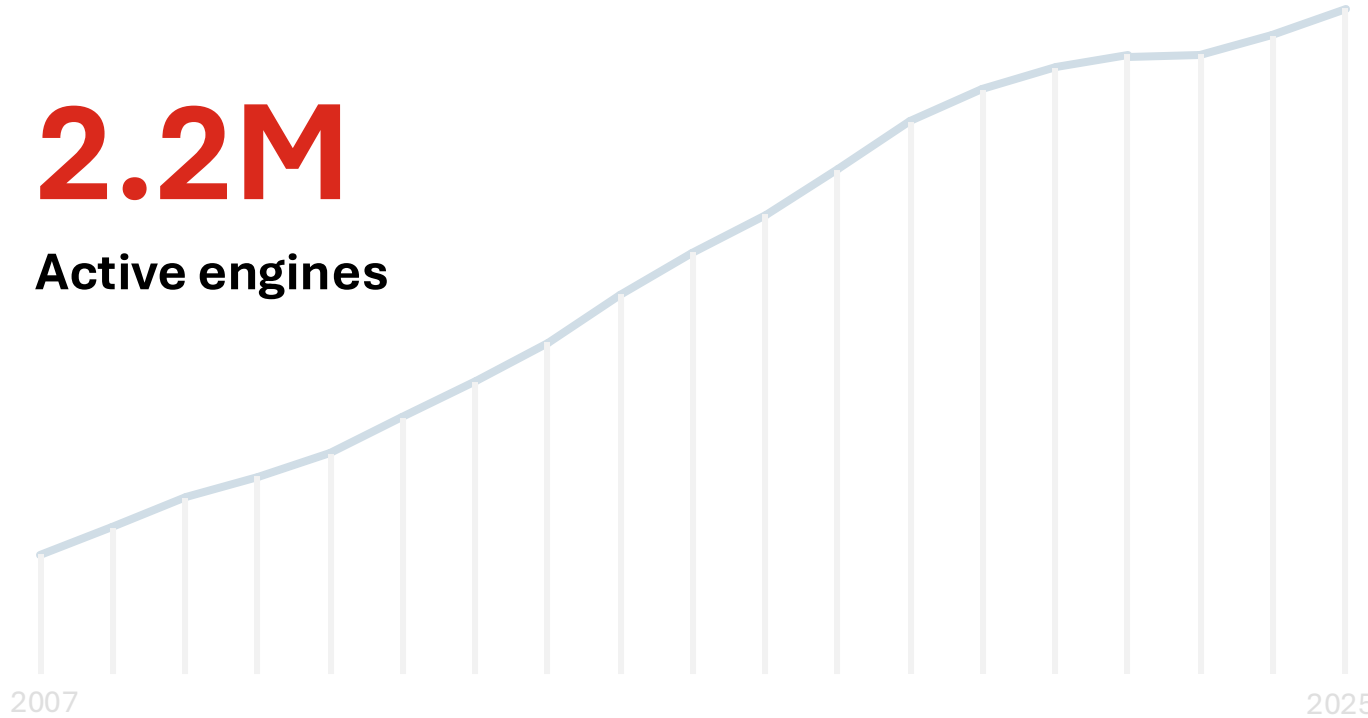

**NORTH AMERICA ON-HIGHWAY ENGINES**  
Medium- and Heavy-Duty

**ENGINE LIFECYCLE**

- Infancy 0-5 years
- Growth 6-9 years
- Mature 10-14 years
- Late life 15+ years

**PARTS CONSUMPTION**

- Medium
- High
- Medium
- Low

**ENGINE BUSINESS**

# A proven strategy delivering higher returns

**Expanding  
engine presence**

**Aftermarket  
annuity growing**

**Peak investment  
behind us**

**DRIVING INCREASING REVENUE AND PROFITABILITY**



**Jenny Bush**  
President, Power Systems Business

# Unlocking Power Systems' Potential

## POWER SYSTEMS BUSINESS

# Transforming our performance



## OPERATIONAL IMPROVEMENT AND FOCUSED STRATEGY

Drove **1,050 basis points** of **margin** improvement



## CAPACITY INVESTMENT

Invested **\$200M** adding **9 GW HHP capacity**



## NEW TECHNOLOGY AND EXPANDED PORTFOLIO

Invested **\$575M** in new product development

# The power of Cummins

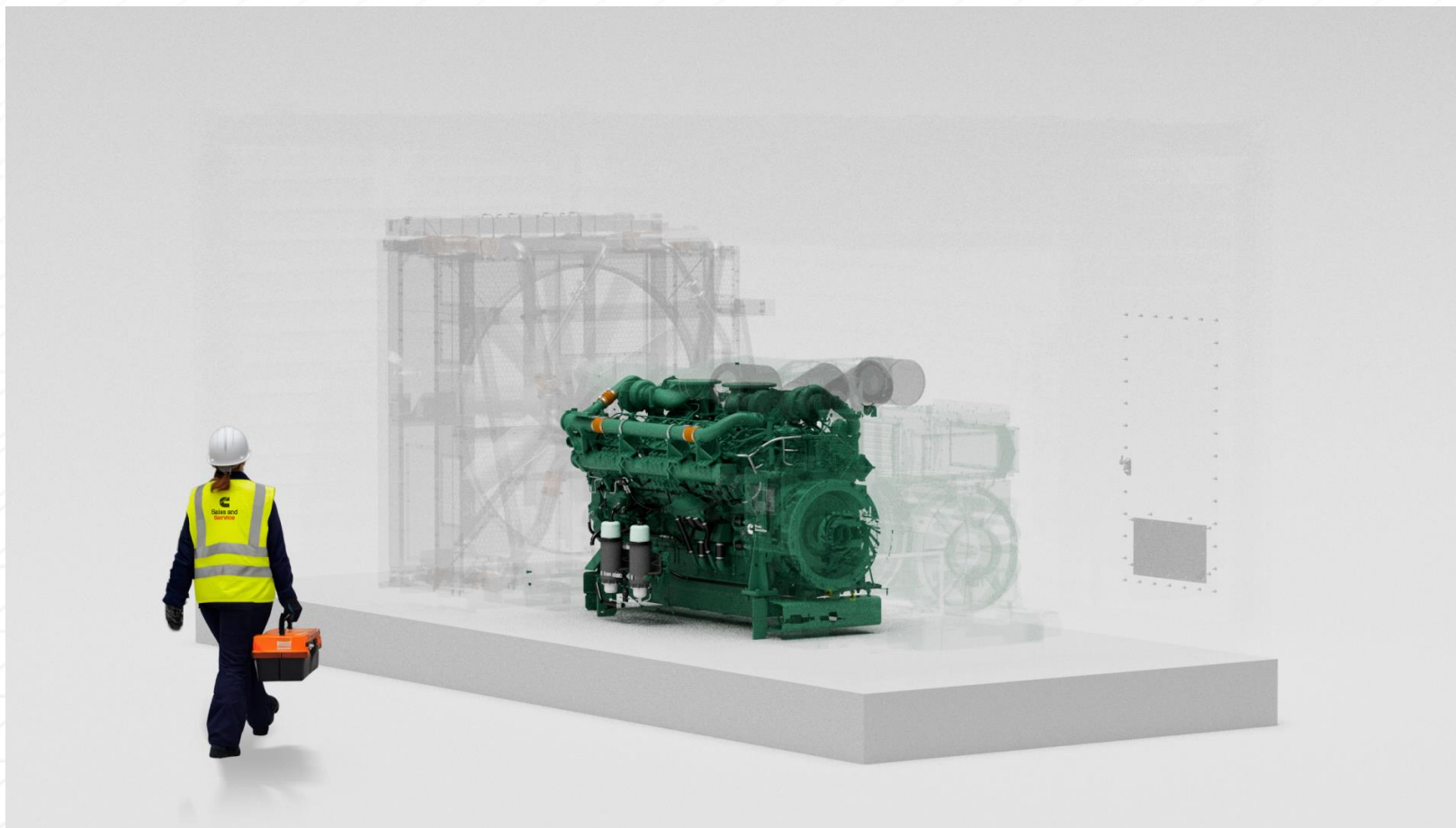

# The power of Cummins

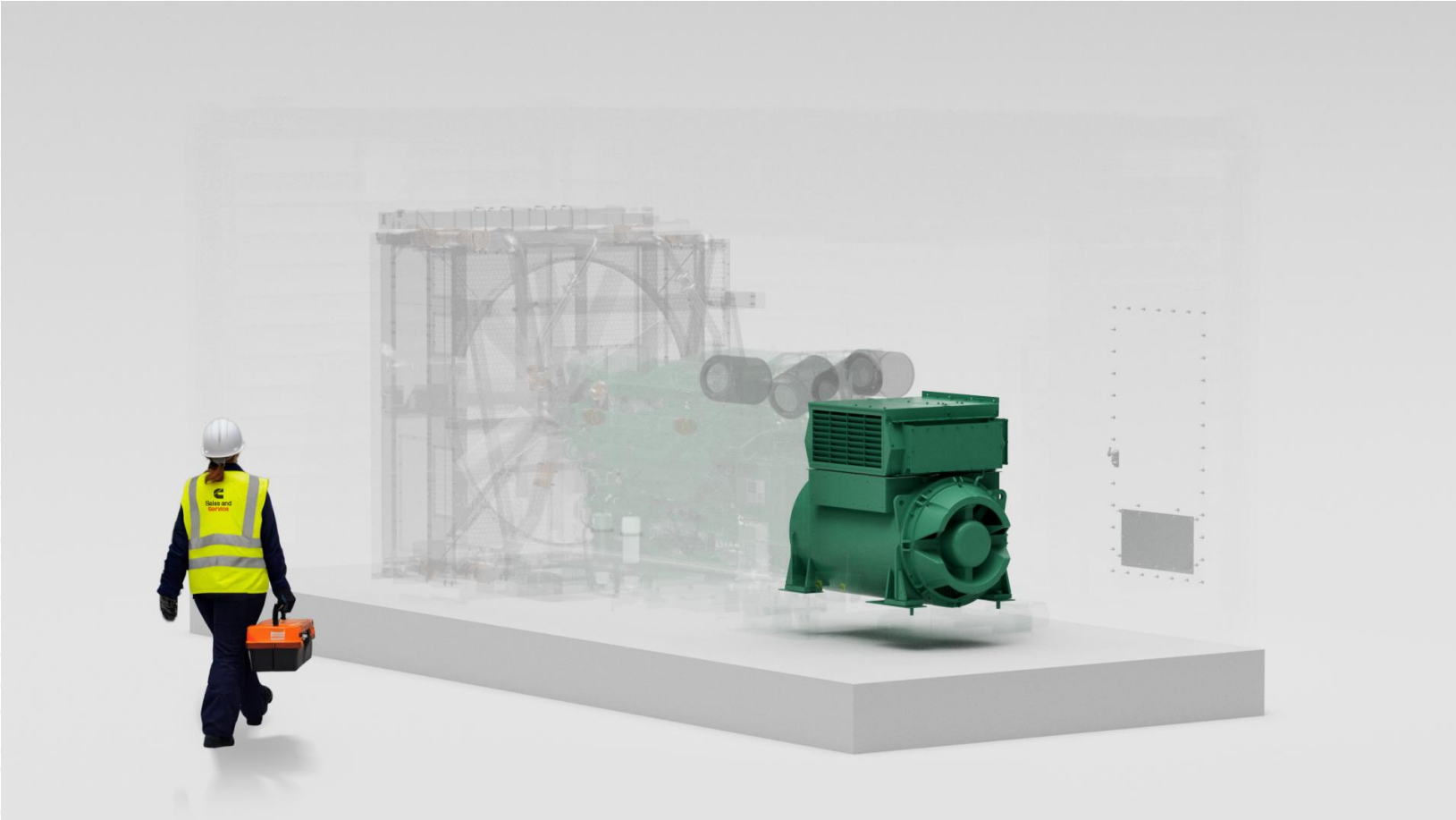

# The power of Cummins

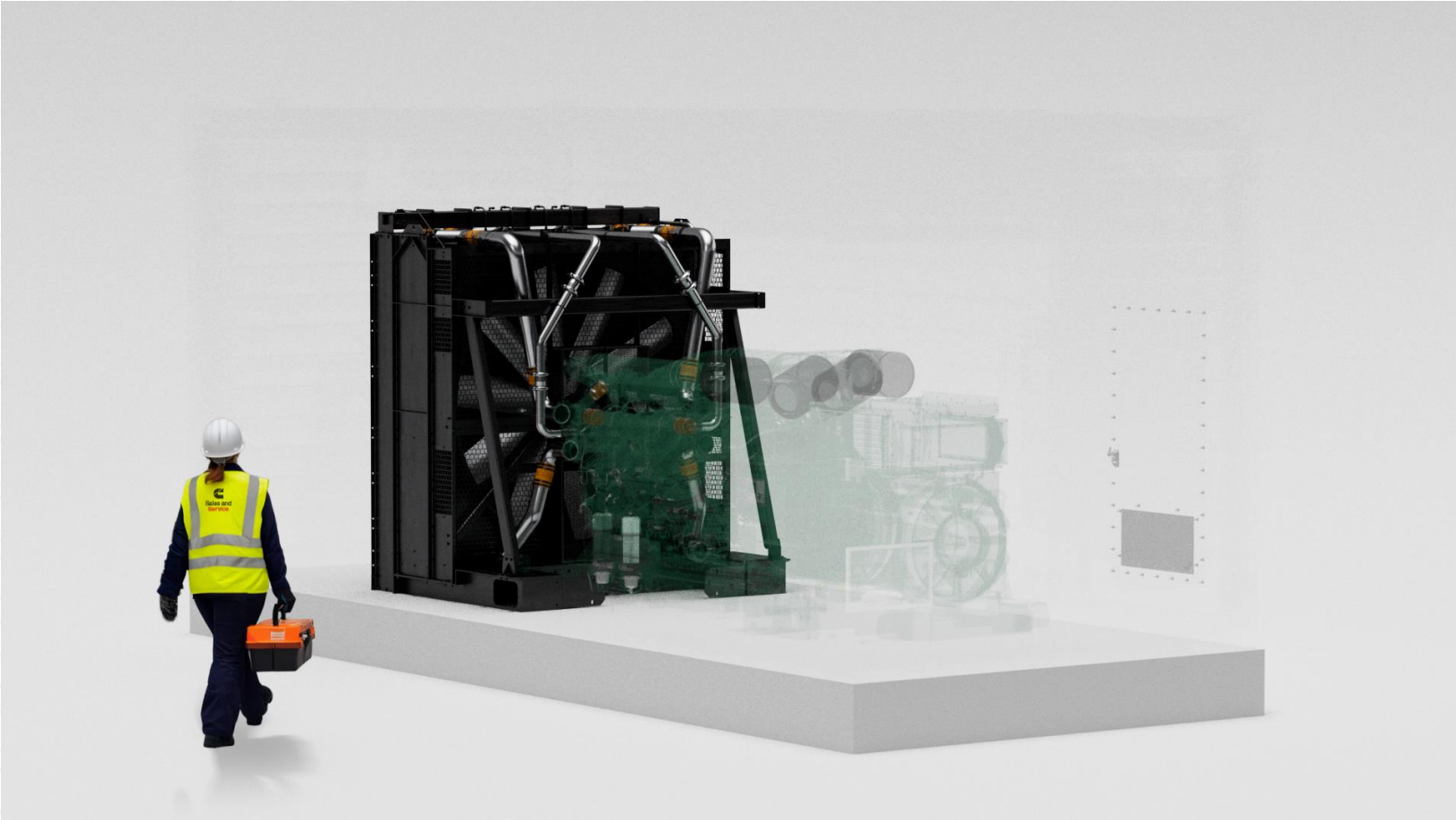

# The power of Cummins

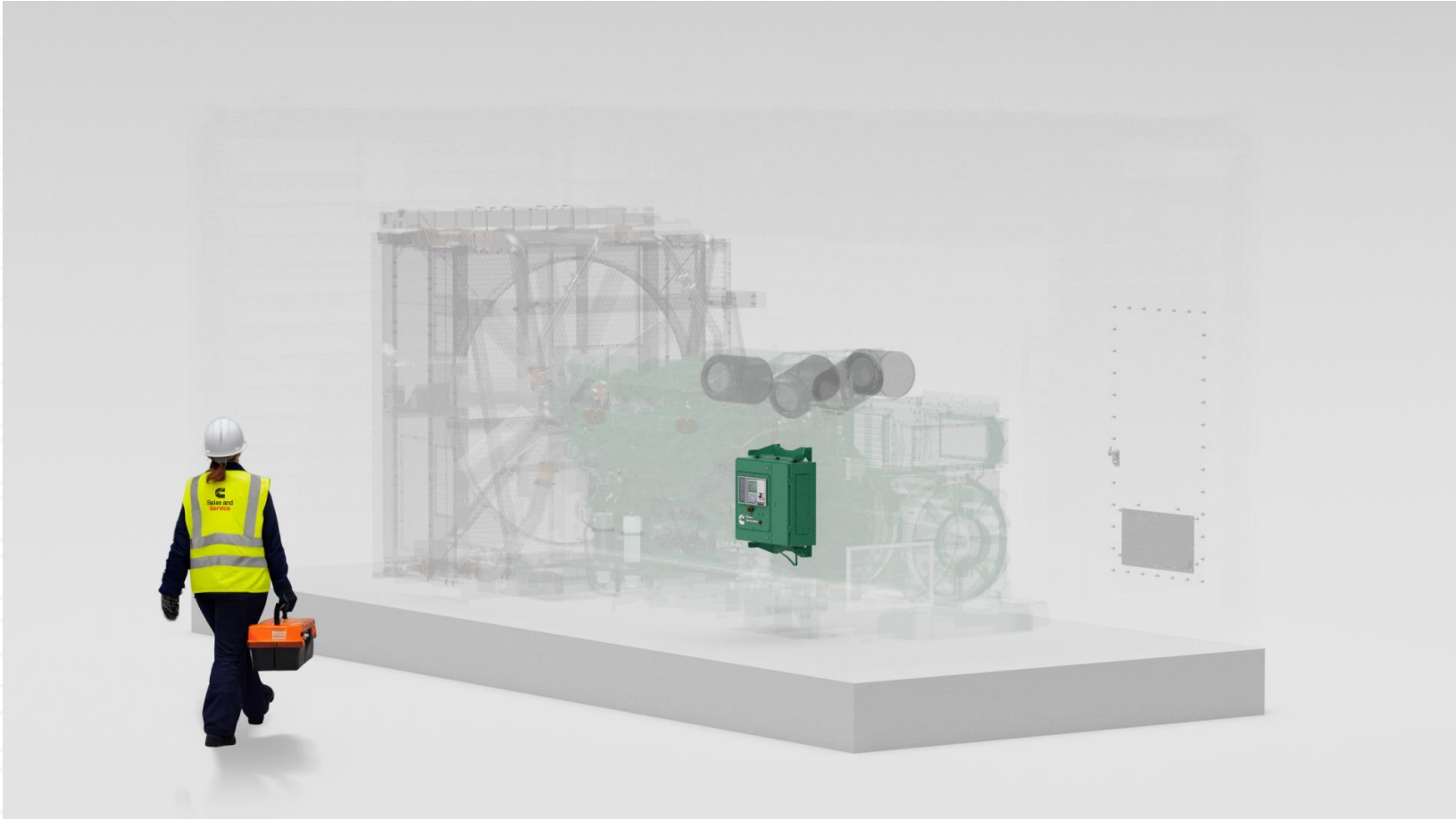

# The power of Cummins

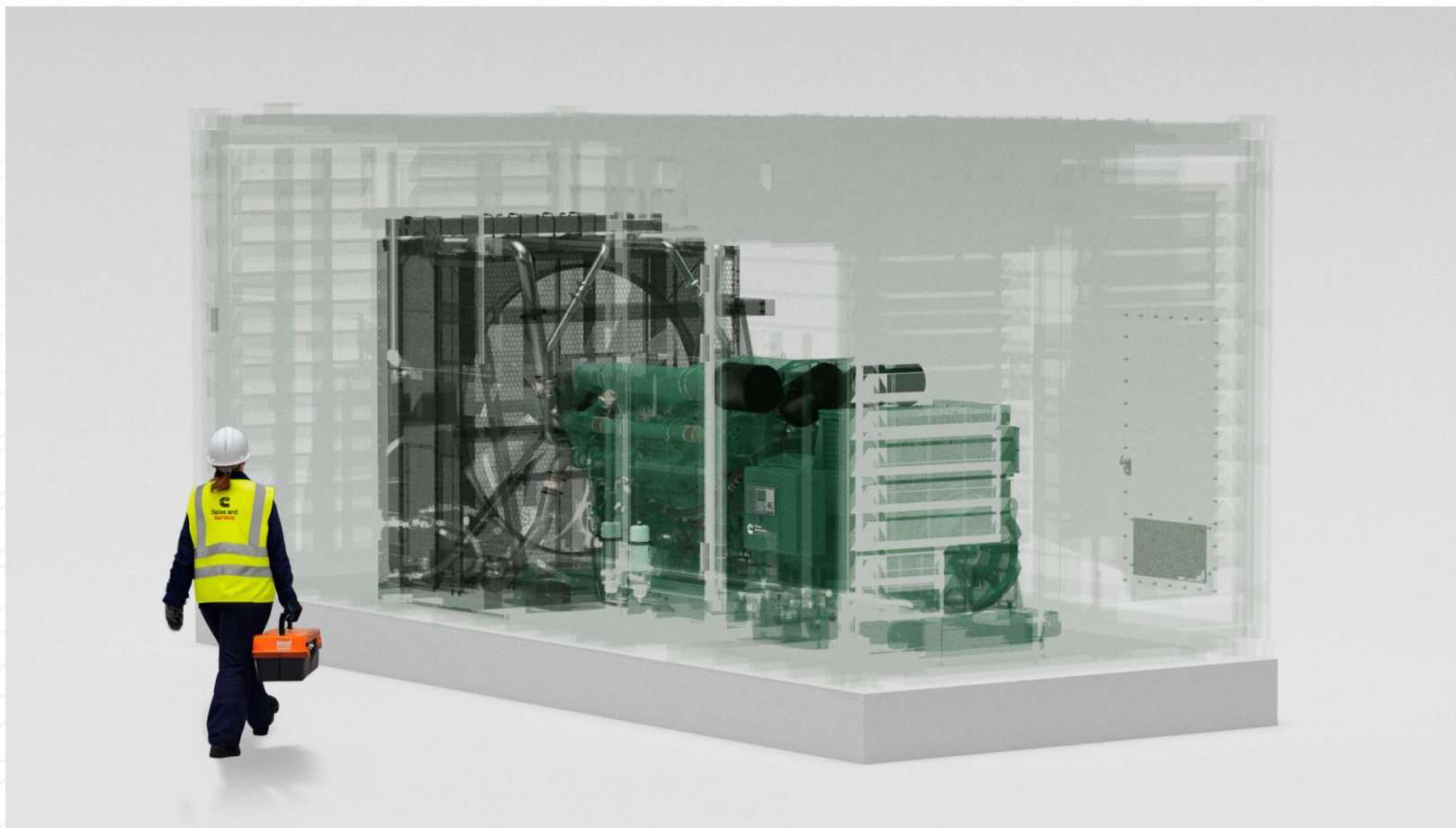

# Stronger growth, higher margins

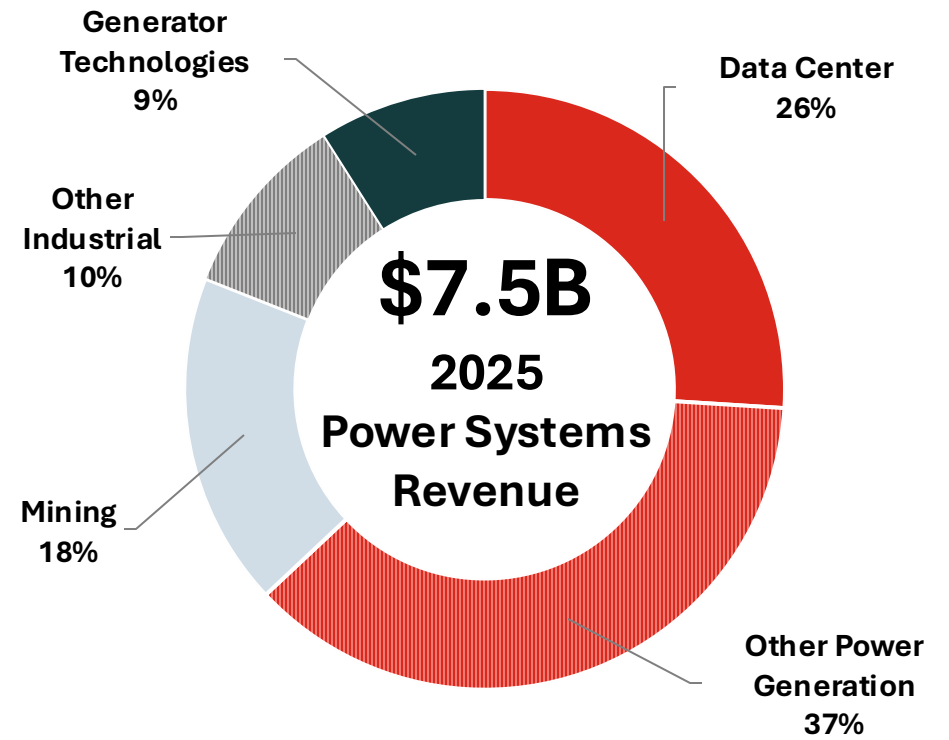
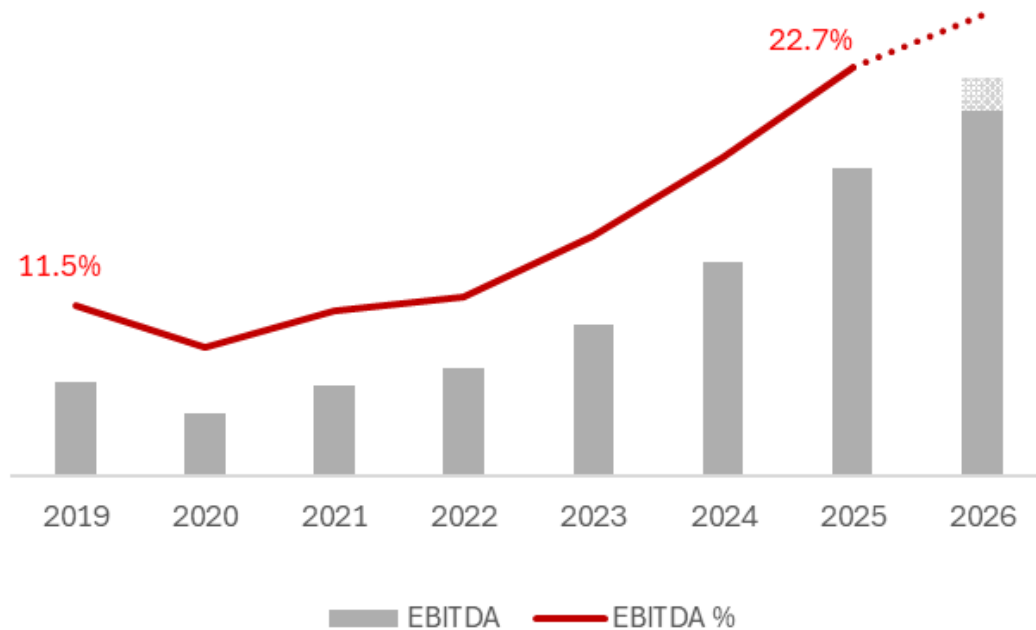

# A proven backup power partner for data centers

- Backup power will remain a non-negotiable for all data center architectures
- We design, engineer and optimize the end-to-end system, providing our customers value in **single partner accountability**

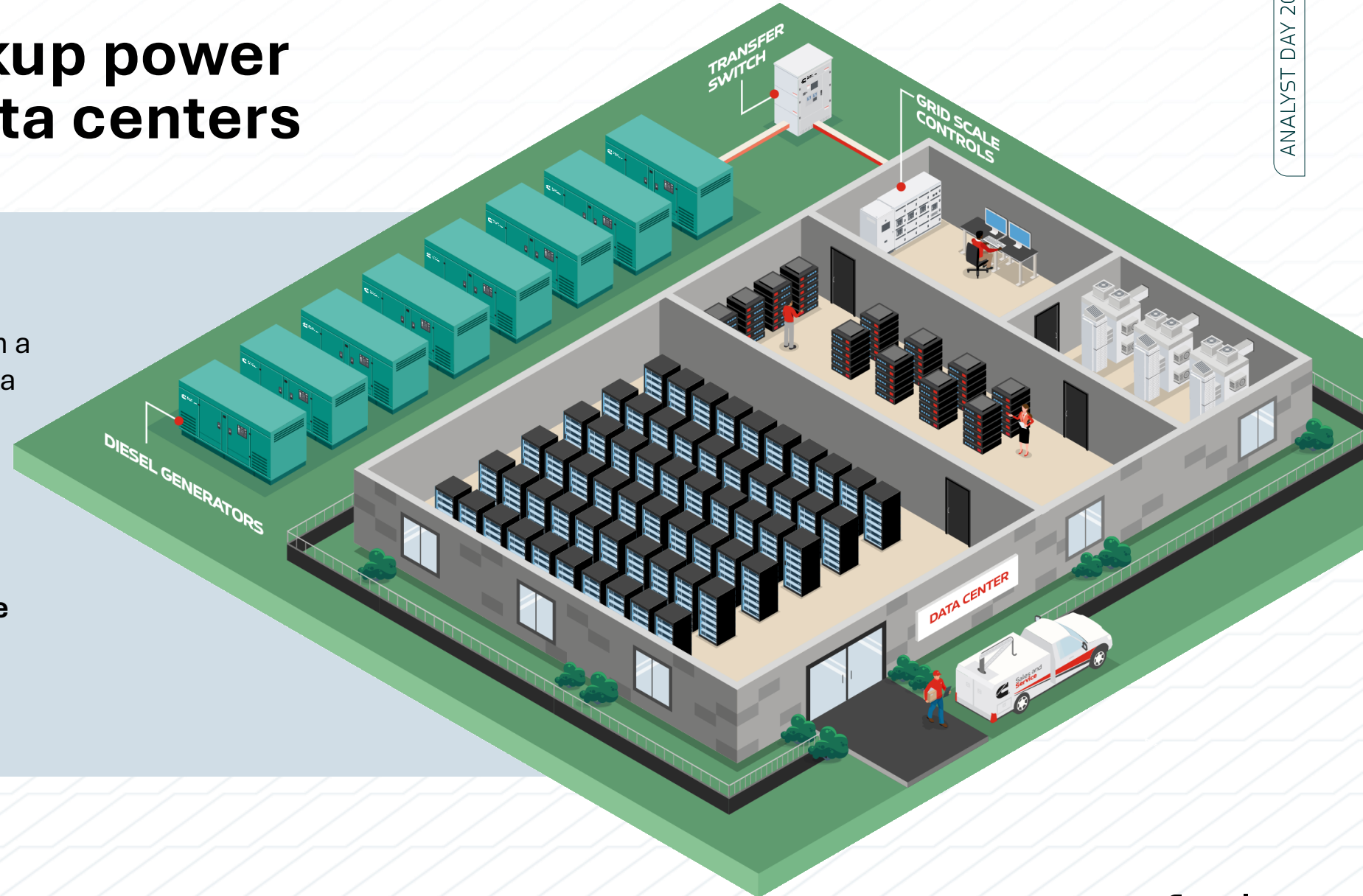

# Scaling backup power growth in data centers

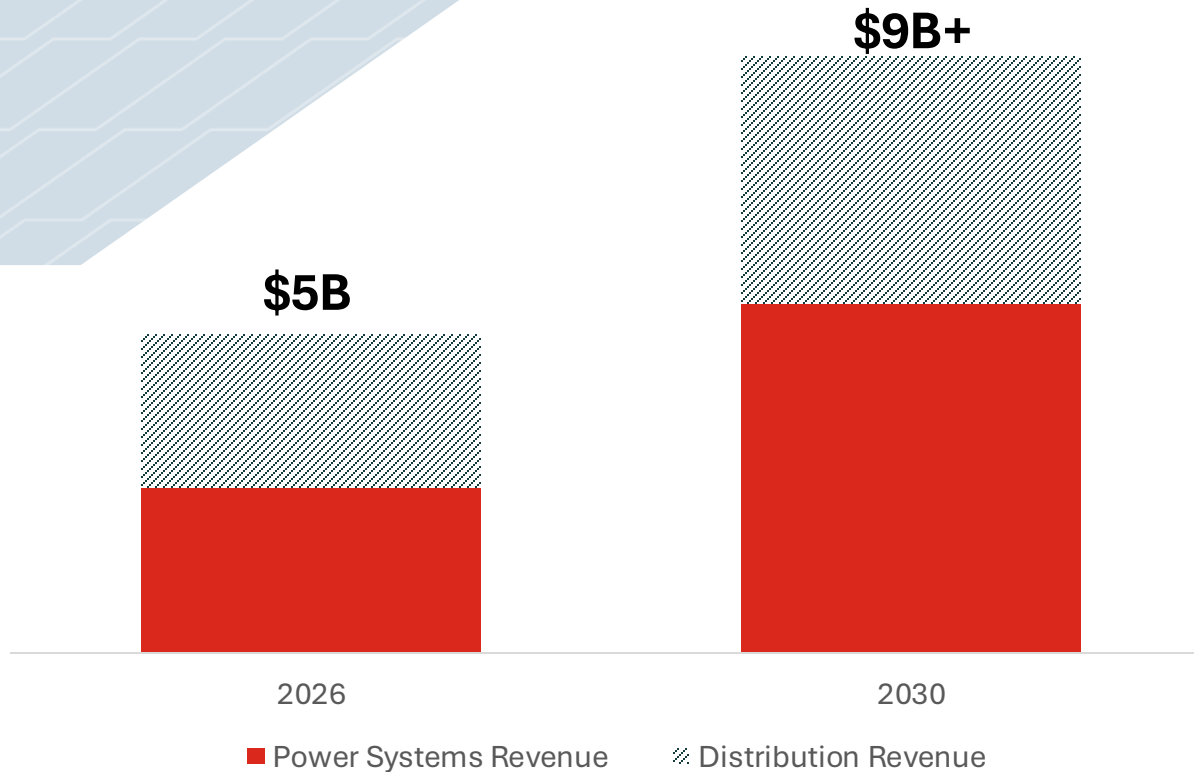

## Supporting continued data center growth

### Our approach:

- Further expanding capacity: **\$450M investment adding 20 additional GW, for a total of 55 GW HHP capacity by 2030**
- Leveraging an integrated operating model and close partnership with our Distribution business

# Navigating a rapidly changing power landscape

- Grid constraints are intensifying and AI demand is increasing power requirements
- When customers' power requirements grow faster than the grid can support, this drives demand for on-site prime power

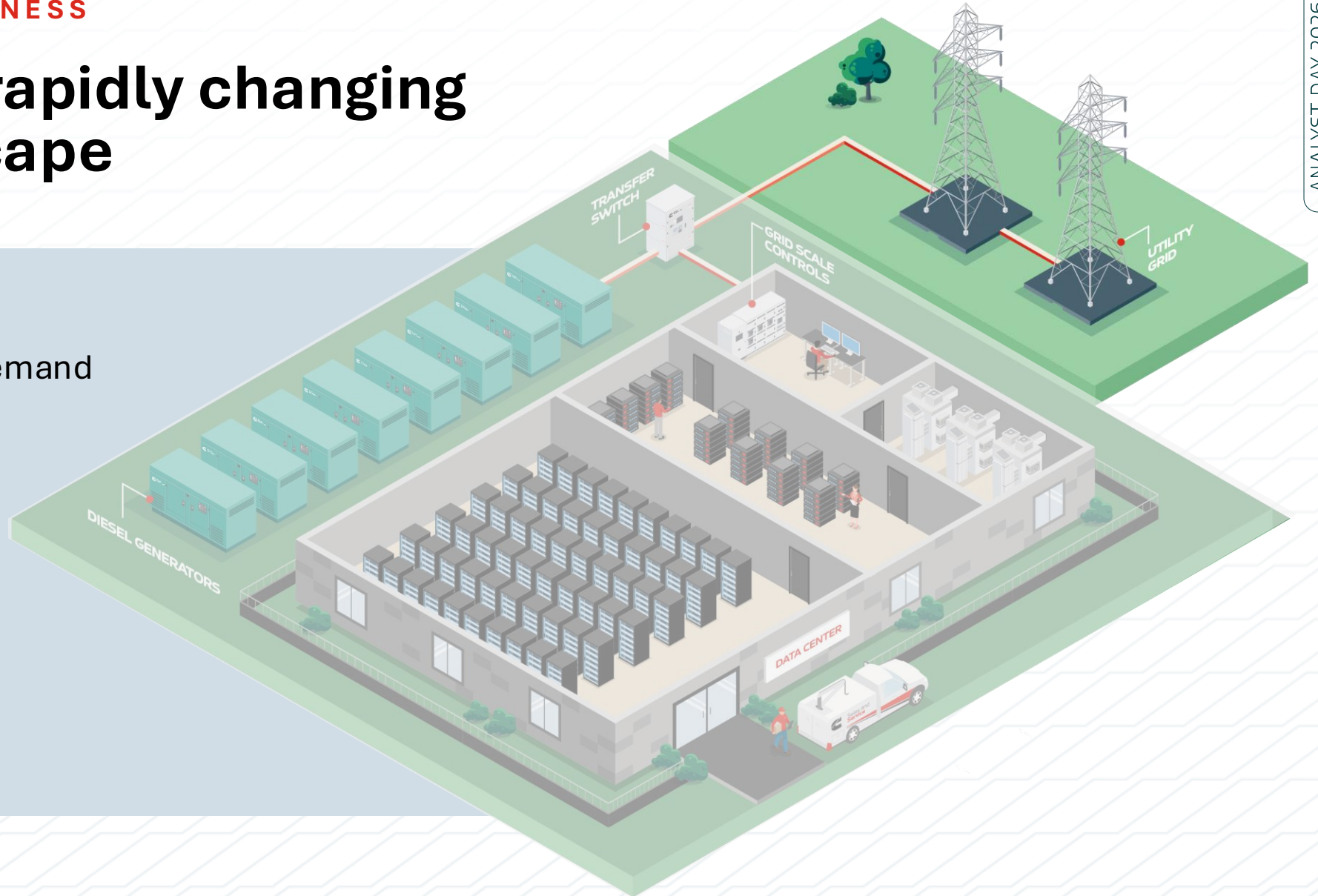

# Expanding beyond backup: Positioning ourselves for prime

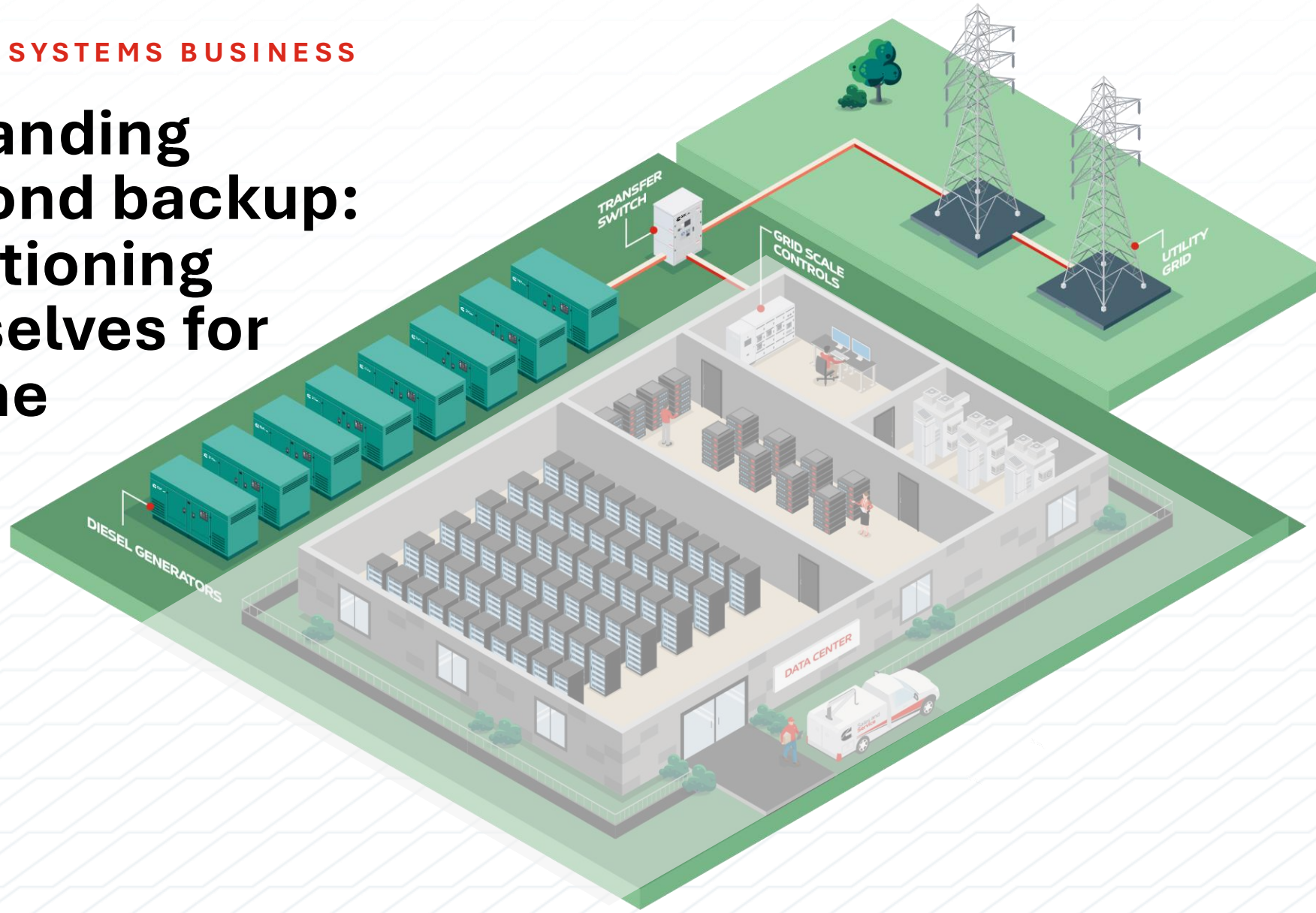

# Expanding beyond backup: Positioning ourselves for prime

Emissions certified  
aftertreatment  
solutions

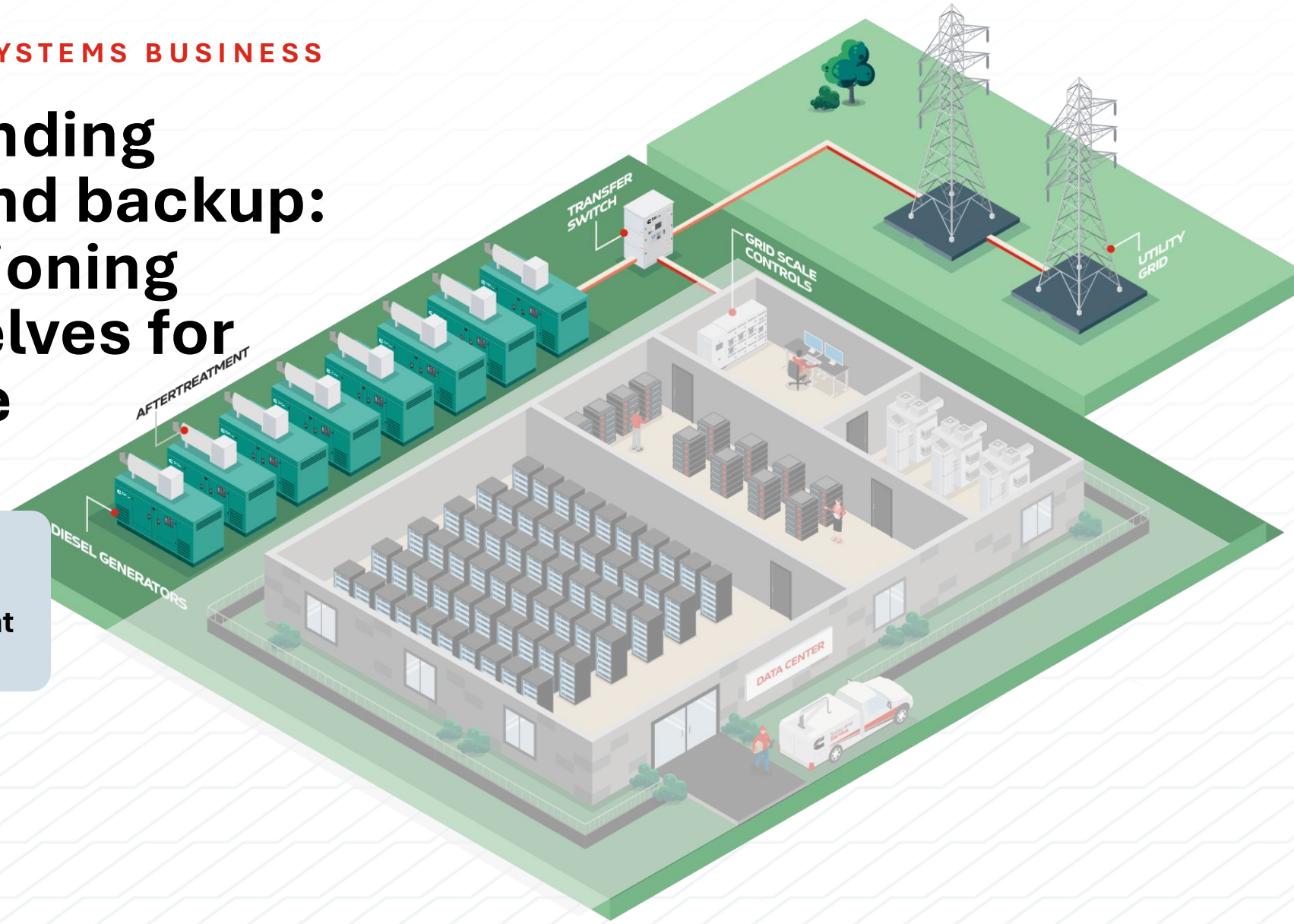

# Expanding beyond backup: Positioning ourselves for prime

Emissions certified aftertreatment solutions

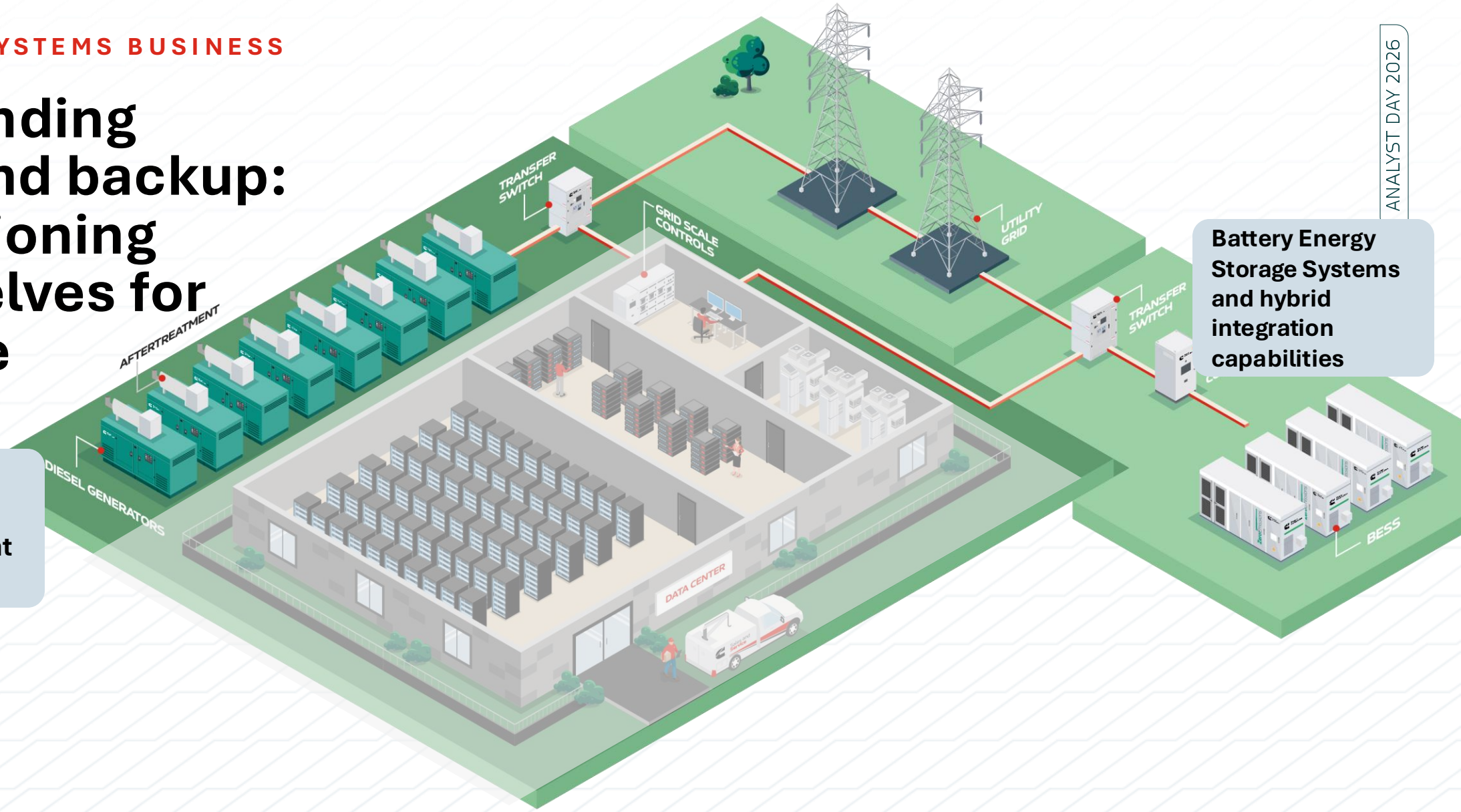

Battery Energy Storage Systems and hybrid integration capabilities

# Expanding beyond backup: Positioning ourselves for prime

Emissions certified aftertreatment solutions

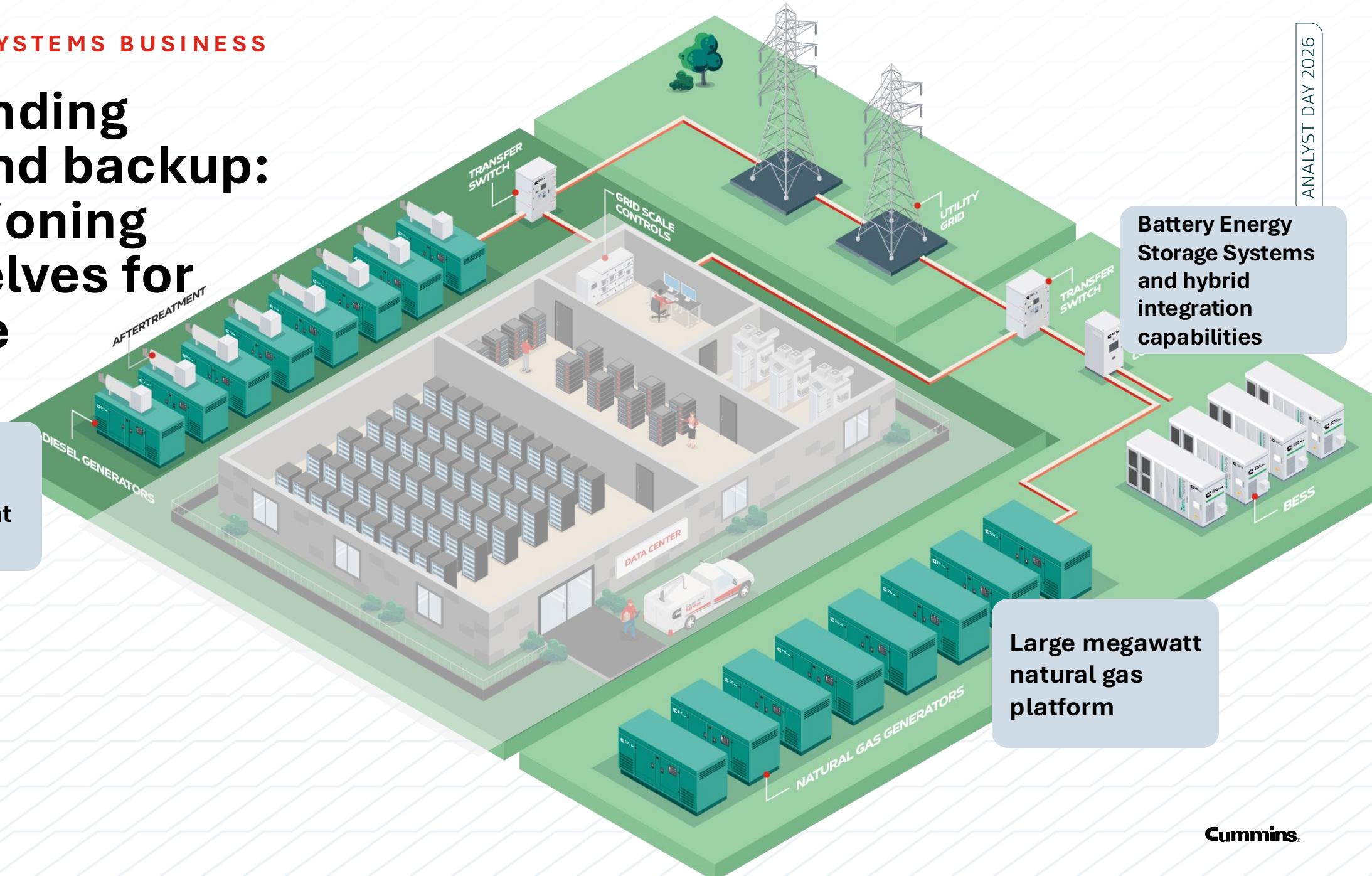

Battery Energy Storage Systems and hybrid integration capabilities

Large megawatt natural gas platform

# Profitable growth to 2030 and beyond



Durable growth in our core standby business across all data center architectures



Further expanding our capacity with \$450M of additional HHP investment



Extending our role behind the meter to support prime power applications

Welcome to

# Analyst Day 2026



# Q+A Panel



**Jennifer Rumsey**  
Chair and Chief Executive Officer



**Brett Merritt**  
President, Engine Business



**Jenny Bush**  
President, Power Systems Business



**Mark Smith**  
Chief Financial Officer



**Amy Davis**  
President, Accelera and  
Components Business



**Shon Wright**  
President, Distribution Business

# Three Conversations. One Lunch.

*Designed for dialogue, with leaders rotating throughout lunch*

## PAIR 1



**Jennifer Rumsey**  
Chair and Chief  
Executive Officer



**Colleen Koeberlein**  
Investor Relations  
Director & Chief of Staff

## PAIR 2



**Mark Smith**  
Chief Financial  
Officer



**Shon Wright**  
President, Distribution  
Business

## PAIR 3



**Jenny Bush**  
President, Power  
Systems Business



**Nick Arens**  
Executive Director,  
Investor Relations

## PAIR 4



**Brett Merritt**  
President,  
Engine Business



**James Hopkins**  
Vice President – Engine  
Business Finance &  
Strategy

## PAIR 5



**Amy Davis**  
President, Accelera  
and Components



**Colin Curtis**  
Investor Relations – Senior  
Financial Analyst

## PAIR 6



**Jeff Wiltrout**  
Vice President –  
Corporate Strategy



**Nicole Lamb-Hale**  
Chief Administrative  
Officer and Corporate  
Secretary

## DISCLOSURE REGARDING FORWARD-LOOKING STATEMENTS

Information provided in this presentation that is not purely historical are forward-looking statements within the meaning of the Private Securities Litigation Reform Act of 1995, including statements regarding our forecasts, guidance, preliminary results, expectations, hopes, beliefs and intentions on strategies regarding the future. These forward-looking statements include, without limitation, statements relating to our plans and expectations for our revenues and EBITDA. Our actual future results could differ materially from those projected in such forward-looking statements because of a number of factors, including, but not limited to: any adverse consequences resulting from entering into agreements with the U.S. Environmental Protection Agency, California Air Resources Board, the Environmental and Natural Resources Division of the U.S. Department of Justice and the California Attorney General's Office to resolve certain regulatory civil claims regarding our emissions certification and compliance process for certain engines primarily used in pick-up truck applications in the U.S., which became final and effective in April 2024, including required additional mitigation projects, adverse reputational impacts and potential resulting legal actions; increased scrutiny from regulatory agencies, as well as unpredictability in the adoption, implementation and enforcement of emission standards around the world; evolving environmental and climate change legislation and regulatory initiatives; any adverse consequences from changes in tariffs and other trade disruptions; changes in international, national and regional trade laws, regulations and policies; emissions deregulation; changes in taxation; global legal and ethical compliance costs and risks; future bans or limitations on the use of diesel-powered products; raw material, transportation and labor price fluctuations and supply shortages; aligning our capacity and production with our demand; the actions of, and income from, joint ventures and other investees that we do not directly control; large truck manufacturers' and original equipment manufacturers' customers discontinuing outsourcing their engine supply needs or experiencing financial distress, or change in control; product recalls; variability in material and commodity costs; the development of new technologies that reduce demand for our current products and services or not successfully developing new technologies and products to effectively address the energy transition; lower than expected acceptance of new or existing products or services; product liability claims; our sales mix of products; climate change, global warming, more stringent climate change regulations, accords, mitigation efforts, greenhouse gas regulations or other legislation designed to address climate change; our plan to reposition our portfolio of product offerings through exploration of strategic acquisitions, divestitures or exiting the production of certain product lines or product categories and related uncertainties of such decisions; increasing interest rates; challenging markets for talent and ability to attract, develop and retain key personnel; exposure to potential security breaches or other disruptions to our information technology environment and data security; the use of artificial intelligence in our business and in our products, services and features, and challenges with properly managing its use; political, economic and other risks from operations among, between and within numerous countries including political, economic and social uncertainty and the evolving globalization of our business; competitor activity; increasing competition, including increased global competition among our customers in emerging markets; failure to meet sustainability expectations or standards, or achieve our sustainability goals; labor relations or work stoppages; foreign currency exchange rate changes; the performance of our pension plan assets and volatility of discount rates; the price and availability of energy; continued availability of financing, financial instruments and financial resources in the amounts, at the times and on the terms required to support our future business; and other risks detailed from time to time in our SEC filings, including particularly in the Risk Factors section of our 2025 Annual Report on Form 10-K and Quarterly Reports on Form 10-Q. Shareholders, potential investors and other readers are urged to consider these factors carefully in evaluating the forward-looking statements and are cautioned not to place undue reliance on such forward-looking statements. The forward-looking statements made herein are made only as of the date of this presentation and we undertake no obligation to publicly update any forward-looking statements, whether as a result of new information, future events or otherwise. More detailed information about factors that may affect our performance may be found in our filings with the SEC, which are available at <https://www.sec.gov> or at <https://www.cummins.com> in the Investor Relations section of our website.

# Adjusted diluted EPS (downturns)

In millions	Twelve months ended				
	31-Dec-25	31-Dec-20	31-Dec-16	31-Dec-09	31-Dec-01
Diluted earnings per share as reported	\$ 20.50	\$ 12.01	\$ 8.23	\$ 2.16	\$ (0.67)
Atmus & one-time items <sup>1</sup>	3.28	(1.61)	(0.81)	—	—
Diluted earnings per share excluding Atmus & one-time items	23.78	10.40	7.42	2.16	(0.67)

<sup>1</sup> 2025 items include \$3.28 per share of Accelera charges; 2020 items include \$1.61 per share of net benefit related to Atmus; 2016 items include \$0.81 per share of net benefit related to Atmus; 2009 items include \$0.33 per share of net benefit related to Atmus and \$0.33 per share of net cost related to restructuring expense and gain related to flood damage recoveries

# Adjusted diluted EPS (peaks)

In millions	Twelve months ended			
	31-Dec-23	31-Dec-19	31-Dec-14	31-Dec-08
Diluted earnings per share as reported	\$ 5.15	\$ 14.48	\$ 9.02	\$ 3.84
Atmus & one-time items <sup>1</sup>	<u>12.85</u>	<u>(0.86)</u>	<u>(0.52)</u>	<u>(0.14)</u>
Diluted earnings per share excluding Atmus & one-time items	18.00	13.62	8.50	3.70

<sup>1</sup> 2023 items include \$13.78 per share of cost related to the agreement to settle with U.S. regulators, \$1.15 per share of net benefit related to Atmus, and \$0.22 per share of cost related to employee voluntary retirement and separation; 2019 items include \$1.43 per share of net benefit related to Atmus and \$0.57 per share of cost related to restructuring expense; 2014 items include \$0.63 per share of net benefit related to Atmus and \$0.11 per share of cost related to restructuring expense and other charges; 2008 items include \$0.42 per share of net benefit related to Atmus and \$0.28 per share of cost related to restructuring expenses, decrease in cash surrender value in corporate owned life insurance and losses related to flood damage recoveries

# Adjusted EBITDA

In millions

	Twelve months ended		
	31-Dec-25	31-Dec-23	31-Dec-16
Net income attributable to Cummins Inc.	\$ 2,843	\$ 735	\$ 1,394
Net income attributable to noncontrolling interests	114	105	62
Consolidated net income	2,957	840	1,456
Income tax expense	1,006	786	474
Income before taxes	3,963	1,626	1,930
Interest expense	329	375	69
EBIT	4,292	2,001	1,999
Depreciation and amortization	1,093	1,016	527
EBITDA	5,385	3,017	2,526
One-time items <sup>1</sup>	458	2,178	—
Less: Atmus EBITDA <sup>2</sup>	—	(354)	(173)
EBITDA excluding Atmus & one-time items	5,843	4,841	2,353

<sup>1</sup> 2025 one-time items include \$458 million of cost related to Accelera charges; 2023 one-time items include \$2.036 billion of cost related to the Settlement Agreements, \$100 million of cost related to the divestiture of Atmus, and \$42 million of cost related to employee voluntary retirement and separation

<sup>2</sup> 2023 Atmus adjustment includes \$354 million of net benefit related to Atmus (net of one-time items); 2016 includes \$173 million of net benefit related to Atmus

We define EBITDA as earnings or losses before interest expense, provision for income taxes, depreciation & amortization, and non-controlling interests in earnings of consolidated subsidiaries. The table above reconciles EBITDA, a non-GAAP financial measure, to our consolidated earnings before income taxes and non-controlling interests, for each of the applicable periods. We believe EBITDA is a useful measure of our operating performance for the periods presented as it illustrates our operating performance without regard for financing methods, capital structure, income taxes, or depreciation & amortization methods. This measure is not in accordance with, or an alternative for, accounting principles generally accepted in the United States of America (GAAP) and may not be consistent with measures used by other companies. It should be considered supplemental data. The table above excludes forward looking measures of EBITDA and EBITDA Margin where a reconciliation to the corresponding GAAP measures is not available due to the variability, complexity and limited visibility of non-cash items that are excluded from the non-GAAP outlook measure.

# Adjusted EBITDA % of total

	Twelve months ended	
	31-Dec-25	31-Dec-16
<b>In millions</b>		
Power Systems Segment EBITDA	\$ 1,694	\$ 378
EBITDA excluding Atmus & one-time items <sup>1</sup>	5,843	2,353
Power Systems Segment EBITDA % of total	29%	16%
Distribution Segment EBITDA	\$ 1,808	\$ 508
EBITDA excluding Atmus & one-time items <sup>1</sup>	5,843	2,353
Distribution Segment EBITDA % of total	31%	22%

<sup>1</sup> 2025 one-time items include \$458 million of cost related to Accelera charges

We define EBITDA as earnings or losses before interest expense, provision for income taxes, depreciation & amortization, and non-controlling interests in earnings of consolidated subsidiaries. The table above reconciles EBITDA, a non-GAAP financial measure, to our consolidated earnings before income taxes and non-controlling interests, for each of the applicable periods. We believe EBITDA is a useful measure of our operating performance for the periods presented as it illustrates our operating performance without regard for financing methods, capital structure, income taxes, or depreciation & amortization methods. This measure is not in accordance with, or an alternative for, accounting principles generally accepted in the United States of America (GAAP) and may not be consistent with measures used by other companies. It should be considered supplemental data. The table above excludes forward looking measures of EBITDA and EBITDA Margin where a reconciliation to the corresponding GAAP measures is not available due to the variability, complexity and limited visibility of non-cash items that are excluded from the non-GAAP outlook measure.

# Invested capital used for return on invested capital calculation

In millions	Twelve months ended					
	31-Dec-25	31-Dec-24	31-Dec-23	31-Dec-22	31-Dec-21	31-Dec-20
Total equity	\$ 13,408	\$ 11,308	\$ 9,904	\$ 9,967	\$ 9,035	\$ 8,707
Less: Defined benefit postretirement plans	(912)	(843)	(848)	(427)	(346)	(735)
Equity used for return on invested capital calculation	14,320	12,151	10,752	10,394	9,381	9,442
Loans payable	313	356	280	210	208	169
Commercial paper	353	1,259	1,496	2,574	313	323
Current maturities of long-term debt	94	660	118	573	59	62
Long-term debt	6,792	4,784	4,802	4,498	3,579	3,610
Unadjusted invested capital used for ROIC calculation	21,872	19,210	17,448	18,249	13,540	13,606
One-time items <sup>1</sup>	—	—	1,436	—	—	—
Adjusted invested capital used for ROIC calculation excluding one-time items	\$ 21,872	\$ 19,210	\$ 18,884	\$ 18,249	\$ 13,540	\$ 13,606

<sup>1</sup> 2023 one-time items include \$2.036 billion of cost related to the Settlement Agreements, less \$600 million of consolidated debt that was transferred upon completion of the Atmus divestiture

A reconciliation of invested capital used for return on invested capital calculation to total equity in our Condensed Consolidated Financial Statements is shown in the table above.

# Net operating profit after taxes used for return on invested capital calculation

In millions	Twelve months ended				
	31-Dec-25	31-Dec-24	31-Dec-23	31-Dec-22	31-Dec-21
Net income attributable to Cummins Inc.	\$ 2,843	\$ 3,946	\$ 735	\$ 2,151	\$ 2,131
Net income attributable to noncontrolling interests	114	122	105	32	33
Consolidated net income	2,957	4,068	840	2,183	2,164
Income tax expense	1,006	835	786	636	587
Income before taxes	3,963	4,903	1,626	2,819	2,751
Interest expense	329	370	375	199	111
EBIT	4,292	5,273	2,001	3,018	2,862
One-time items <sup>1</sup>	458	(957)	2,178	192	—
EBIT excluding one-time items	4,750	4,316	4,179	3,210	2,862
Less: Tax effect on EBIT	1,083	932	978	706	610
Net operating profit after taxes used for return on invested capital calculation	\$ 3,667	\$ 3,384	\$ 3,201	\$ 2,504	\$ 2,252

<sup>1</sup> 2025 one-time items include \$458 million of cost related to Accelera charges; 2024 one-time items include \$1.298 billion of net benefit related to the divestiture of Atmus, \$312 million of cost related to the Accelera reorganization, and \$29 million of restructuring expenses; 2023 one-time items include \$2.036 billion of cost related to the Settlement Agreements, \$100 million of cost related to the divestiture of Atmus, and \$42 million of cost related to employee voluntary retirement and separation; 2022 one-time items include \$111 million of cost related to the indefinite suspension of operations in Russia and \$81 million of cost related to the divestiture of Atmus

A reconciliation of net operating profit after taxes used for return on invested capital calculation to net income attributable to Cummins Inc. in our Condensed Consolidated Financial Statements is shown in the table above.

# Adjusted ROIC

In millions	Twelve months ended				
	31-Dec-25	31-Dec-24	31-Dec-23	31-Dec-22	31-Dec-21
<b>UNADJUSTED ROIC</b>					
Net operating profit after taxes	\$ 3,202	\$ 4,377	\$ 1,035	\$ 2,336	\$ 2,252
Beginning - Unadjusted invested capital used for ROIC calculation	19,210	17,448	18,249	13,540	13,606
Ending - Unadjusted invested capital used for ROIC calculation	21,872	19,210	17,448	18,249	13,540
Unadjusted ROIC	16%	24%	6%	15%	17%
<b>ADJUSTED ROIC</b>					
Net operating profit after taxes excluding one-time items <sup>1</sup>	3,667	3,384	3,201	2,504	2,252
Beginning - Adjusted invested capital used for ROIC calculation	19,210	18,884	18,249	13,540	13,606
Ending - Adjusted invested capital used for ROIC calculation <sup>2</sup>	21,872	19,210	18,884	18,249	13,540
Adjusted ROIC	18%	18%	17%	16%	17%

<sup>1</sup> 2025 one-time items include \$455 million of cost related to Accelera charges; 2024 one-time items include \$1.291 billion of net benefit related to the divestiture of Atmus, \$296 million of cost related to the Accelera reorganization, and \$22 million of restructuring expenses; 2023 one-time items include \$1.966 billion of cost related to the Settlement Agreements, \$77 million of cost related to the divestiture of Atmus, and \$32 million of cost related to employee voluntary retirement and separation; 2022 one-time items include \$102 million of cost related to the indefinite suspension of operations in Russia and \$64 million of cost related to the divestiture of Atmus

<sup>2</sup> 2023 one-time items include \$2.036 billion of cost related to the Settlement Agreements, less \$600 million of consolidated debt that was transferred upon completion of the Atmus divestiture

# Revenue

**In millions**

	Twelve months ended	
	31-Dec-25	31-Dec-23
Net sales	\$ 33,670	\$ 34,065
Less: Atmus net sales <sup>1</sup>	—	1,629
Net sales excluding Atmus	33,670	32,436

<sup>1</sup> 2023 Atmus adjustment includes \$1.629 billion of net sales related to Atmus

# Adjusted EBITDA %

	Twelve months ended	
	31-Dec-25	31-Dec-23
Net income attributable to Cummins Inc.	% 8.4	% 2.2
Net income attributable to noncontrolling interests	0.3	0.3
Consolidated net income	8.7	2.5
Income tax expense	3.0	2.3
Income before taxes	11.7	4.8
Interest expense	1.0	1.1
EBIT	12.7	5.9
Depreciation and amortization	3.3	3.0
EBITDA	16.0	8.9
One-time items <sup>1</sup>	1.4	6.4
Less: Atmus EBITDA <sup>2</sup>	0.0	(0.4)
EBITDA excluding Atmus & one-time items	17.4	14.9

<sup>1</sup> 2025 one-time items include \$458 million of cost related to Accelera charges; 2023 one-time items include \$2.036 billion of cost related to the Settlement Agreements, \$100 million of cost related to the divestiture of Atmus, and \$42 million of cost related to employee voluntary retirement and separation

<sup>2</sup> 2023 Atmus adjustment includes \$354 million of net EBITDA benefit related to Atmus (net of one-time items) as well as \$1.629 billion of net sales related to Atmus

We define EBITDA as earnings or losses before interest expense, provision for income taxes, depreciation & amortization, and non-controlling interests in earnings of consolidated subsidiaries. The table above reconciles EBITDA, a non-GAAP financial measure, to our consolidated earnings before income taxes and non-controlling interests, for each of the applicable periods. We believe EBITDA is a useful measure of our operating performance for the periods presented as it illustrates our operating performance without regard for financing methods, capital structure, income taxes, or depreciation & amortization methods. This measure is not in accordance with, or an alternative for, accounting principles generally accepted in the United States of America (GAAP) and may not be consistent with measures used by other companies. It should be considered supplemental data. The table above excludes forward looking measures of EBITDA and EBITDA Margin where a reconciliation to the corresponding GAAP measures is not available due to the variability, complexity and limited visibility of non-cash items that are excluded from the non-GAAP outlook measure.