

Tecofrost

Natural Gas Engine Driven Refrigeration

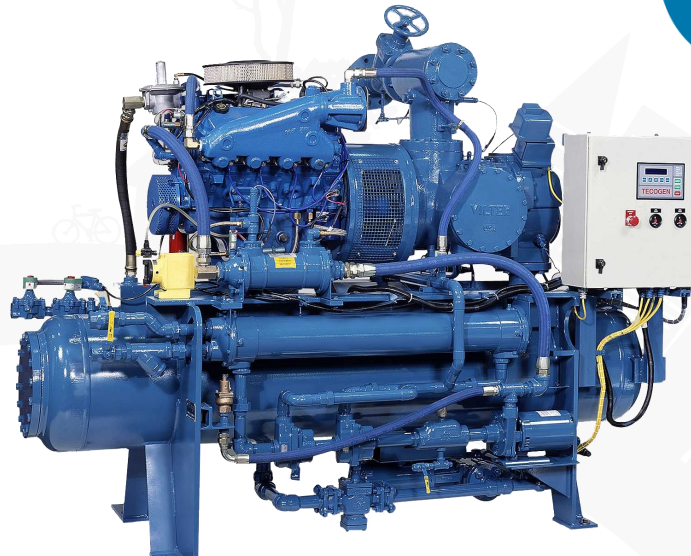

SUCCESSFUL APPLICATIONS INCLUDE:

Cold Food Storage

Food Processors

Bakeries

Beef, Pork & Poultry

Breweries

Dairies

Wineries

Ice Production

Ice Rinks

Industrial Process

Pharmaceutical

Petrochemical

MAXIMUM OPERATING SAVINGS

In many regions, the total cost of meeting refrigeration load by natural gas is substantially less than the cost of using electricity. The variable speed operation of the TecoDrive natural gas engine used on the Tecofrost optimizes energy use by closely following the load profile. This variable speed capability provides additional benefits of longer intervals between required maintenance on both the engine and compressor. This annual operating savings is significant and yields a rapid payback. Utility, state, and federal incentives available in many areas.

AVOID HIGH DEMAND AND ENERGY CHARGES

Refrigeration plants have extremely large electrical demand and usage loads. In many application's this load peaks in the daytime and summer, the same periods when electricity is the most expensive and natural gas supply is the most abundant. By reducing the refrigeration plant electric demand and usage during these periods, owners can save significantly in their total energy costs through the entire year.

UTILIZE ENGINE AND EXHAUST WASTE HEAT FOR HOT WATER OR PROCESS NEEDS

Maximum savings can be realized by utilizing the heat generated by the engine jacket and exhaust gas. Recovered heat can be used for space heating, domestic hot water, boiler feed water preheating, or process applications. Nearly one-half of the engine's fuel consumption can be recovered through this waste heat and is available up to 225°F.

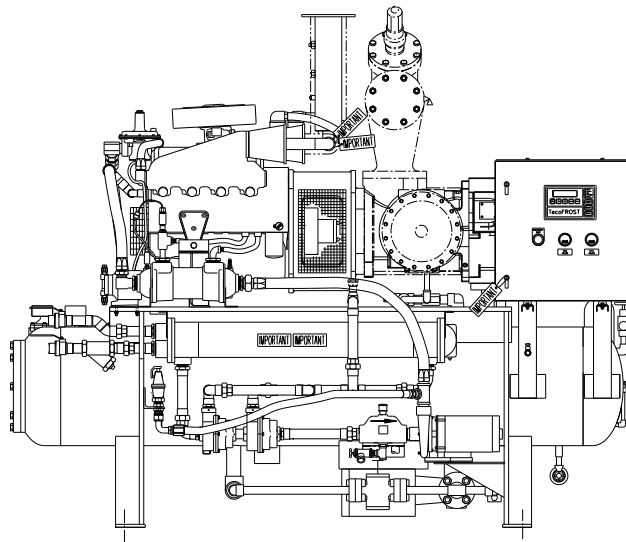
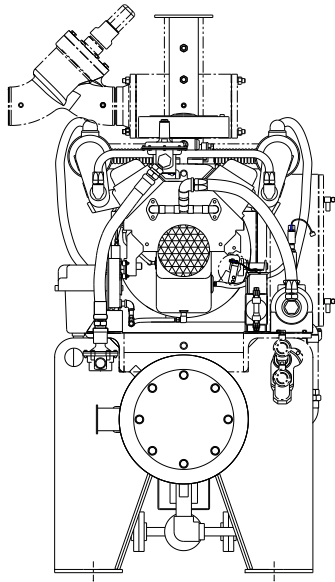

PHYSICAL DIMENSIONS

Length (L):	8'9"
Width (W):	4'3"
Height:	7'4"
Weight:	4,000 lbs

DIMENSION NOTES:

- All dimensions are approximate and subject to change; consult factory for most current installation drawings.
- Minimum Service Clearances:
 - 3 feet on all sides for routine service
 - 2 feet above unit for engine and compressor removal.

VSM 501@ 3000 rpm for R-717

Water-cooled Oil Cooling

		SDT [°F/psig]															
		75/125.8				85/151.7				95/181.1				105/181.1			
SST [°F]	psig	TR	BHP	Fuel [MBtu/h]	EHR [MBtu/h]	TR	BHP	Fuel [MBtu/h]	EHR [MBtu/h]	TR	BHP	Fuel [MBtu/h]	EHR [MBtu/h]	TR	BHP	Fuel [MBtu/h]	EHR [MBtu/h]
-40	8.8*	28	81	848	445	26	90	916	481	23	101	993	523	21	111	1074	566
-30	1.6*	41	90	917	482	38	101	997	525	35	113	1085	572	33	125	1176	620
-20	3.6	57	98	975	513	54	111	1071	564	51	124	1169	617	48	139	1280	675
-10	9	76	107	1042	549	73	118	1127	594	70	134	1246	657	66	151	1368	723
0	15.7	99	117	1112	586	95	130	1215	641	92	144	1317	696	(see Note 5)			
10	23.8	128	123	1163	613	123	140	1287	679								
20	33.5	162	127	1188	627	157	147	1339	707								
30	45	204	128	1194	630	197	150	1358	717								
40	58.6	Insufficient pressure ratio				245	150	1358	717	(see Note 5)							

* inches of mercury below one atmosphere

Notes

- All specifications are +/- 5% and subject to change without notice.
- Rating are based on 10 °F suction superheat and 10 °F liquid subcooling.
- Fuel (MBH) = natural gas fuel consumption base on higher heating value of 1020 Btu/scf.
- EHR (MBH) = Engine & Exhaust Heat Recovery.
- Ratings must be determined with partially open slide valve so as not to exceed maximum engine horsepower. Assume 150 HP for economic analysis.

OUTSTANDING TECOFROST FEATURES

- TecoDrive™ 7400 industrial, natural gas engine
- Reliable and robust single screw compressor by Vilter
- Variable VI (volume ratio)
- Equivalent footprint to electric packages
- Service sprint mode

- Variable engine speed operation for excellent part load performance and longer life
- TecoNET™ microprocessor-based control system with precise PID control for fully automatic operation, continuous system monitoring, digital display, fault diagnostics and tie-in to an

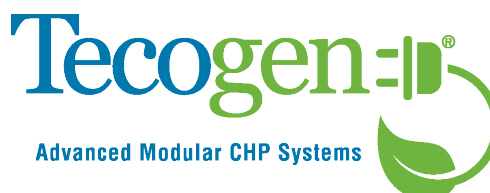

TECOGEN®, Tecofrost™ and TecoDrive™ are trademarks of Tecogen Inc.