

C30 Microturbine

High-pressure Natural Gas



Achieve ultra-low emissions and reliable electrical generation from natural gas.

- + Ultra-low emissions
- + One moving part – minimal maintenance and downtime
- + Patented air bearings – no lubricating oil or coolant
- + Integrated utility synchronization – no external switchgear⁽¹⁾
- + Compact modular design allows for easy, low-cost installation
- + Multiple units easily combined – act as single generating source
- + Remote monitoring and diagnostic capabilities
- + Proven technology with tens of millions of operating hours
- + Various Factory Protection Plans available



C30 Microturbine

Electrical Performance⁽²⁾

Electrical Power Output	30kW
Voltage	400/480 VAC
Electrical Service	3-Phase, 4 Wire Wye
Frequency	50/60 Hz
Electrical Efficiency LHV	26%

Fuel/Engine Characteristics⁽²⁾

Natural Gas HHV	30.7–47.5 MJ/m ³ (825 –1,275 BTU/scf)
Inlet Pressure	379– 414 kPa gauge (55– 60 psig)
Fuel Flow HHV	457 MJ/hr (433,000 BTU/hr)
Net Heat Rate LHV	13.8 MJ/kWh (13,100 BTU/kWh)

Exhaust Characteristics⁽²⁾

NOx Emissions @ 15% O ₂	< 9 ppmvd (18 mg/m ³)
Exhaust Mass Flow	0.31 kg/s (0.69 lbm/s)
Exhaust Gas Temperature	275°C (530°F)

Dimensions & Weight⁽³⁾

Width x Depth x Height ⁽⁴⁾	0.76 x 1.52 x 1.79 m (30 x 60 x 71 in)
Weight - Grid Connect Model	405 kg (891 lb)
Weight - Dual Mode Model	578 kg (1,271 lb)

Reliable power when and where you need it. Clean and simple.

Minimum Clearance Requirements⁽⁵⁾

Horizontal Clearance	
Left & Right	0.76 m (30 in)
Front	0.93 m (37 in)
Rear	0.90 m (35 in)

Acoustic Emissions

Nominal at Full Power at 10 m (33 ft)	65 dBA
---------------------------------------	--------

Certifications

- UL 2200 Listed
- CE Certified

C30 Engine Components

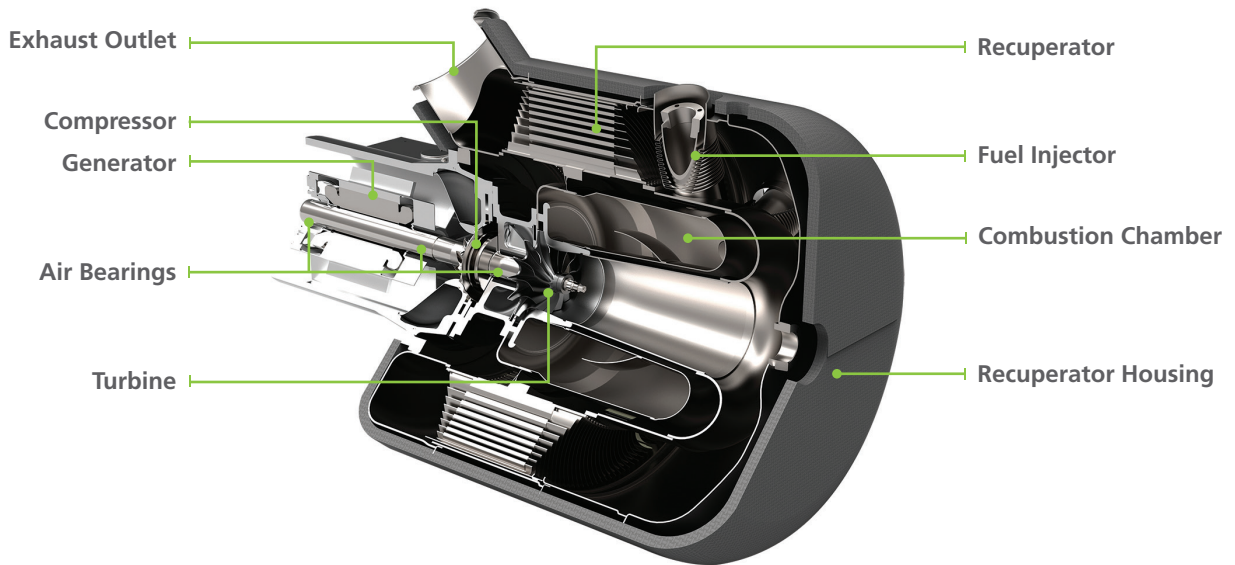

(1) Some utilities may require additional equipment for grid interconnectivity
 (2) Nominal full power performance at ISO conditions: 15°C (59°F), 14.696 psia, 60% RH
 (3) Approximate dimensions and weights
 (4) Height dimensions are to the roofline. Exhaust stack extends at least 178 mm (7 in) above the roofline
 (5) Clearance requirements may increase due to local code considerations
 Specifications are not warranted and are subject to change without notice.

