

C1000S Power Package

Low-pressure Natural Gas, ICHP



The Signature Series Microturbine provides ultra-low emissions and reliable electrical/thermal generation from natural gas.

- + Ultra-low emissions
- + One moving part – minimal maintenance and downtime
- + Patented air bearings – no lubricating oil or coolant
- + Integrated utility synchronization – no external switchgear
- + Internal fuel gas compressor housed within enclosure
- + Compact modular design allows for easy, low-cost installation
- + High electrical efficiency over a very wide operating range
- + High availability – part load redundancy
- + Remote monitoring and diagnostic capabilities
- + Proven technology with tens of millions of operating hours
- + Various Factory Protection Plans available



C1000S ICHP Power Package

Electrical Performance⁽¹⁾

Electrical Power Output	950kW
Voltage	400/480 VAC
Electrical Service	3-Phase, 4 Wire Wye
Frequency	50/60 Hz
Electrical Efficiency LHV	31%

Fuel/Engine Characteristics⁽¹⁾

Natural Gas HHV	35.4–42.8 MJ/m ³ (950–1,150 BTU/scf)
Inlet Pressure	1.7–34.5 kPa gauge (0.25–5.0 psig)
Fuel Flow HHV	12,150 MJ/hr (11,500,000 BTU/hr)
Net Heat Rate LHV	11.6 MJ/kWh (11,000 BTU/kWh)

Exhaust Characteristics⁽¹⁾

NO _x Emissions @ 15% O ₂	< 9 ppmvd (18 mg/m ³)
Exhaust Mass Flow	6.7 kg/s (14.7 lbm/s)
Exhaust Gas Temperature	280°C (535°F) (Heat Recovery Bypassed)

Dimensions & Weight⁽²⁾

Width x Depth x Height	3.0 x 9.1 x 4.0 m (117 x 360 x 157 in)
Weight - Grid Connect Model, dry	22,600 kg (49,800 lbs)
Weight - Dual Mode Model, dry	26,100 kg (57,500 lbs)

Reliable power when and where you need it. Clean and simple.

Minimum Clearance Requirements⁽³⁾

Horizontal Clearance	
Left	1.5 m (60 in)
Right	0.0 m (0 in)
Front	1.7 m (65 in)
Rear	2.2 m (85 in)

ICHP Heat Recovery⁽⁴⁾

Hot Water Heat Recovery	1.5 MW (5.1 MMBtu/hr)
-------------------------	-----------------------

Certifications

- UL 2200 Listed
- CE Certified
- Certified to the following grid interconnection standards: UL 1741-SA, VDE, BDEW, CEI 0-16 and AS4447
- Compliant to California Rule 21

C200 Engine Components

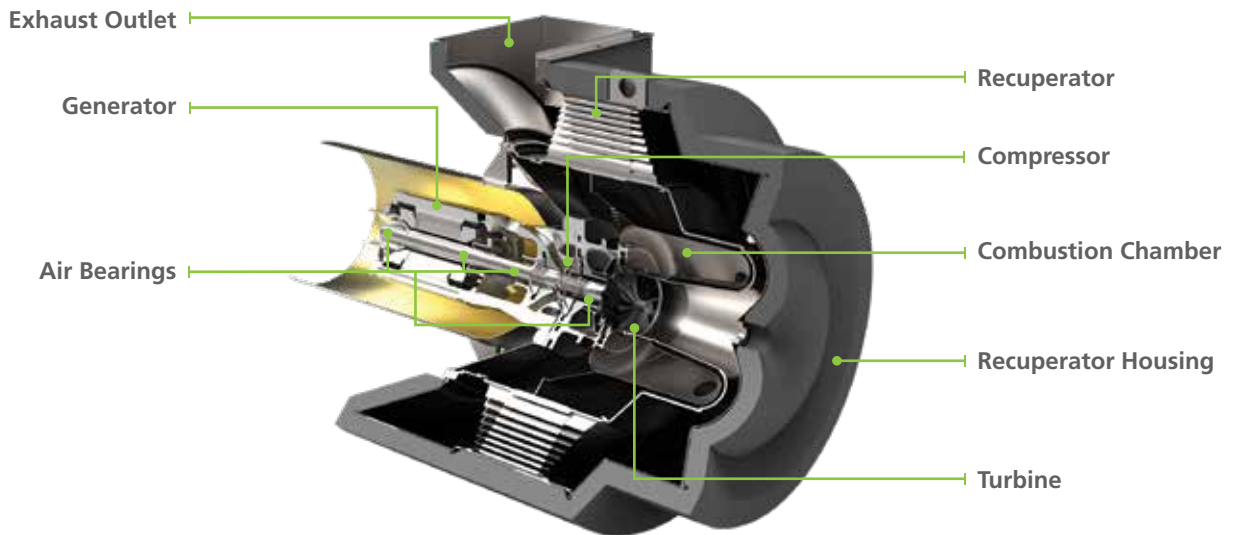

(1) Nominal full power performance at ISO conditions: 15°C (59°F), 14.696 psia, 60% RH

(2) Approximate dimensions and weights

(3) Clearance requirements may increase due to local code considerations

(4) Nominal heat recovery using 5 Heat Recovery Modules (HRM). Inlet water temperature of 38°C (100°F) and flow rate of 6.3 l/s (100 gpm) per HRM. Specifications are not warranted and are subject to change without notice.

