

CG-5100 IMU

emcore®

EMCORE's Commercial Inertial Measurement Unit Solution



Key Features

- EMCORE's patented Digital Signal Processing (DSP) FOGs for high reliability and stable performance
- Highly accurate rate and acceleration data
- Designed to meet COTS requirements
- Measures roll, pitch, and yaw angular rates and accelerations
- Fiber optic gyro stability
- Affordable, compact design
- Excellent shock and vibration performance

Applications

- Antenna, optical, and camera stabilization
- GPS augmentation
- Autonomous vehicles
- Drilling
- Navigation
- Motion sensing

CG-5100 – The Complete Position, Velocity, and Attitude Solution

The versatile EMCORE CG-5100 Inertial Measurement Unit (IMU) combines proprietary technologies – highly accurate fiber optic gyro (FOG)-based sensors coupled with industry proven MEMS accelerometers – all within a compact single enclosure, providing reliability and long-term compliance to customer specifications. Through its seamless integration of these two highly reliable navigation components, the CG-5100 provides a ground-breaking low-cost, small form factor solution for inertial measurement.

The EMCORE sensor engine of FOGs and accelerometers creates a flexible and efficient IMU, a high performance motion sensing package ideally suited for critical sensing applications and GPS integrated navigation programs. This strap-down inertial subsystem offers outstanding reliability and accurate 6-degrees-of-freedom measurement. The CG-5100 achieves its excellent performance by employing proprietary algorithms to a fully digital gyro sensor output, enabling the system to characterize and correct for the effects of temperature and misalignment. The CG-5100 also affords the end user with a convenient and easy to adapt output in a fully digital RS-232/RS-422 format.

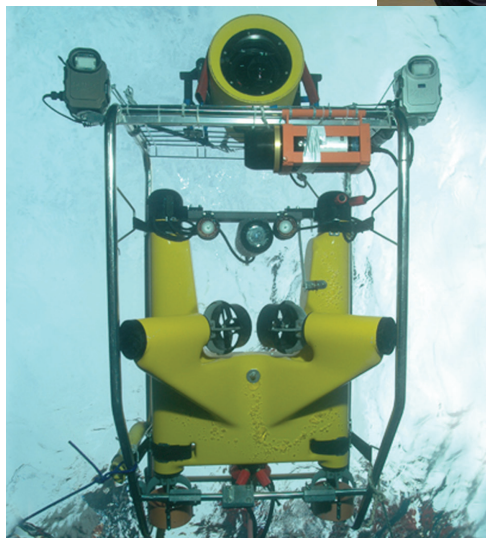
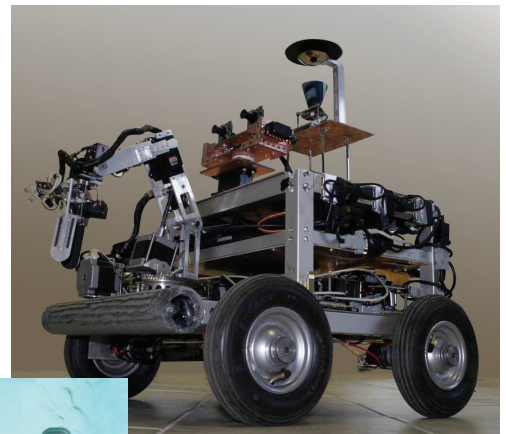

The CG-5100 technology is ideal for precise positioning, even in challenging environments.

EMCORE CG-5100 Fiber Optic Gyro IMU

Performance Specifications

Input Rate (<i>max</i>)	±375°/sec
Bias Instability (25°C)	≤1°/hr, 1σ
Bias vs. Temperature (≤1°C/min)	≤6°/hr, 1σ
Bias Offset (25°C)	±20°/hr
Scale Factor Non-linearity (<i>max rate</i> , 25°C)	≤1000 ppm, 1σ
Scale Factor vs. Temperature (≤1°C/min)	≤500 ppm, 1σ
Angle Random Walk (25°C)	≤0.067°/√hr (≤4°/hr/√Hz)
Bandwidth (-3 dB)	≥100 Hz

Electrical/Mechanical

Initialization Time (<i>valid data</i>)	≤5 secs
Data Interface	Asynchronous RS-422 or RS-232
Baud Rate	115.2 Kbps
Data Rate	100 Hz
Dimensions (<i>max</i>)	169.4 mm L x 152.4 mm W x 88.9 mm H (6.67" x 6" x 3.5")
Weight (<i>max</i>)	2.27 kg (5 lbs)
Power Consumption	15 W
Input Voltage	+9 to +18 VDC

Environment

Temperature (<i>operating</i>)	-40°C to +65°C (-40°F to +149°F)
Shock (<i>operating</i>)	7 g, 11 msec, half-sine
Vibration (<i>operating</i>)	8 g rms, 20-2000 Hz, random

Accelerometers

Input Limit (<i>max</i>)	±10 g
Bias Instability (<i>constant temp</i>)	<0.25 mg, 1σ
Scale Factor Temperature Sensitivity	1000 ppm/°C, 1σ
Velocity Random Walk (25°C)	≤0.12 mg/√Hz (0.23 ft/sec/√hr)
Bandwidth (-3 dB)	50 Hz ±5%

For detailed interface control drawings (ICD) and technical manuals on this product, please visit emcore.com/nav/support

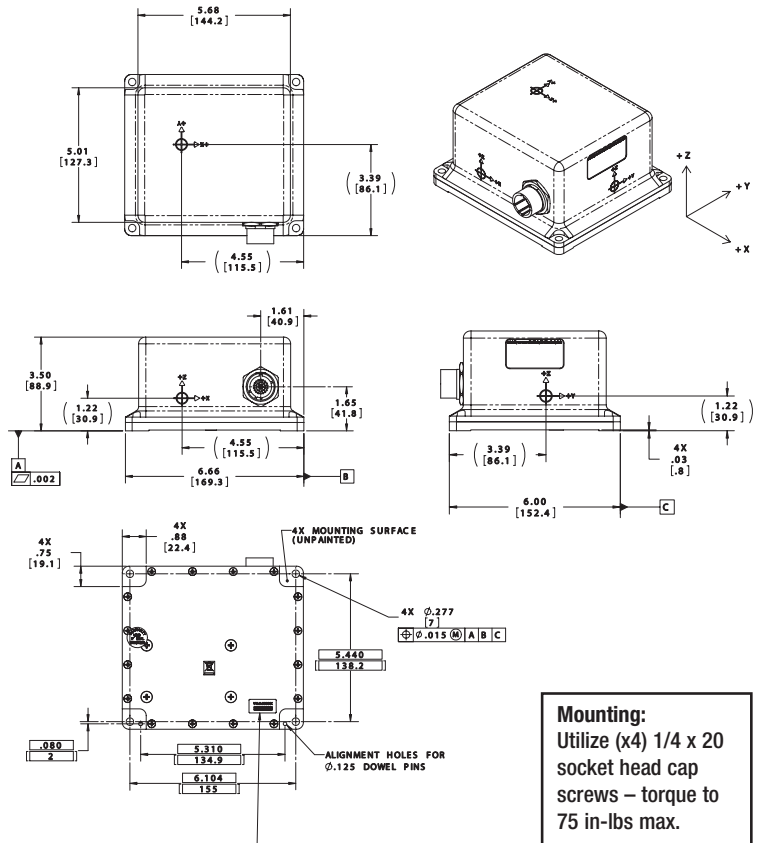

EMCORE's CG-5100 is ideal for autonomous vehicle applications

For More Information

+1 866.234.4976 | emcore.com/nav | navigation-sales@emcore.com

EMCORE Corporation
2015 Chestnut Street, Alhambra, CA U.S.A.
P +1 626.293.3700 F +1 626.293.3429

